



# HALIFAX SOIL & DRAIN



*Mechanically Jointed Cast Iron Systems*

## TECHNICAL GUIDE

*Fully Compliant with*

**BS EN 877:1999 + A1:2006**

**BS EN 877:2021**



[www.soilandrain.co.uk](http://www.soilandrain.co.uk)

# CONTENTS

## Technical Information

<b>1.0 System Overview</b>	4
1.1 System Overview	4
1.2 Certification	4
1.3 Professional Bodies	4
1.4 Key Standards, Codes & Regs	5
1.5 Benefits of Halifax Soil & Drain	5-6
1.6 Product Range	6
1.7 Responsible Production & Training	6
1.8 Ongoing Inspection & Training	6
<b>2.0 Reaction to Fire</b>	7
2.1 Fire Rating Summary	7
2.2 Definitions	8
<b>3.0 Acoustic Performance</b>	9
3.1 Fraunhofer IBP Guidelines	9
3.2 Noise Transmission	9-10
3.3 Testing	10-11
<b>4.0 Dimensions &amp; Mechanical Properties</b>	12
4.1 Products Dimensions	12
4.2 Physical Attributes of Cast Iron	13
4.3 Pipe Weights	13
4.4 Physical Properties from EN 877	13-14
4.5 Pipe Gradients & Filling Capacities	14-16
<b>5.0 Product Coating &amp; Appearance</b>	17
5.1 Halifax Soil Pipes	17
5.2 Halifax Soil Fittings	17
5.3 Halifax Drain Pipes	18
5.4 Halifax Drain Fittings	18
5.5 Chemical Resistance of Coatings	19-20
5.6 Product Markings	21-22
5.7 Buried Pipelines	22
5.8 Concrete Encasement	22
<b>6.0 Couplings</b>	23
6.1 Joint Tests	23
6.2 Ductile Iron Couplings	23
6.3 Rapid Connect Couplings	24
6.4 High Performance Couplings	24
6.5 Halifax Push Fit Coupling	24
6.6 Electrical Continuity	25

<b>7.0 Brackets</b>	26
7.1 Support Intervals	26
7.2 Coated Adjustable Brackets	27
7.3 Rubber Lined Bismats	27
7.4 Heavy Duty Bossed	27
7.5 Stack Support Brackets	28
7.6 Acoustic Dampener	28
7.7 Console Bracket	28
<b>8.0 Pipe System Design Guidance</b>	29
<b>9.0 Connecting to Other Systems</b>	30
9.1 Equivalent Systems	30
9.2 Conventional Soil / Drain Systems	30
9.3 Threaded Connections	30
9.4 Compression Fit Boss	30
9.5 Manifold Connectors	31

## Product Tables

<b>Halifax Soil Product Tables</b>	32
Double Spigot Pipes	33
Ductile Iron Couplings	33
Rapid Connect Couplings	33
Push Fit Couplings	33
Bends	34-36
Branches	37-39
Access Pipes	40
P - Traps	40
Offsets	41
Pipe Tapers	41
Blank Ends	41
Threaded Boss Pipes	42
Compression Fit Boss Pipes	42
Manifold Connector	43
Stack Support Pipe	43
Stack Support Pipe Bracket	43
Stack Support Console	43
Coated Adjustable Bracket	44
Halifax Grip	44



# CONTENTS

## Halifax Soil Product Tables Continued..

Bismat Bracket	44
Heavy Duty Bossed Bracket	44
Heavy Duty Bossed Bracket Lined	45
Split Band Clip	45
High Performance Coupling	45
Heavy Duty Bossed Bracket Lined	45

## Halifax Soil Sundries

Wall Plate	46
Thread Adaptor	46
Galv. Cantilever Arms	46
Rapid Strut Cantilever Arm	46
Acoustic Dampener	46

## Halifax Drain Product Tables

Double Spigot Pipes	48
Ductile Iron Couplings	48
Push Fit Couplings	48
Bends	49-50
Branches	51-52
Access Pipes	53
Pipe Tapers	53
Coated Adjustable Brackets	53
P - Traps	54
Blank Ends	54
Gullies	55
Grates	55
Covers	55
Puddle Flanges	55
Inspection Chambers	56

## Installation

<b>Safe Practice</b>	58
Ductile Iron Couplings	59
Rapid Connect Couplings	60
Push Fit Couplings	61

## Above Ground Installation

Securing Brackets to Walls	62
Vertical Pipework Support	62
LG Horizontal Pipework Support	63
Acoustic Dampener	63

## Above Ground Installation

Securing Brackets to Walls	62
Vertical Pipework Support	62
LG Horizontal Pipework Support	63
Acoustic Dampener	63
Manifold Connectors	64

## Below Ground Installation

Buried Pipelines	65
Trench Preparation	65
Concrete Encasement	65
Bedding in Concrete	65
Settlement	66
Depth of Pipework	66
Pipe Falls	66
Provision for Access	66
Puddle Flanges	67
Cutting Pipes	67
Touching Up	67

## Mods & Testing of Installations

68-69

## Certs & DoP's

BSI Kitemark	70
DoP's	71-78

## 1. System Summary

### 1.1 System Overview

Halifax Soil & Drain is a socketless, mechanically jointed cast iron drainage and wastewater system. It is designed to minimise installation difficulties and maintenance costs over its lifetime.

Cast iron drainage products are proven to be reliable, durable and strong. They are safe, noncombustible, quiet and with minimal maintenance will last the life of a building. Cast iron is sustainable and can be fully recycled without any loss of its original properties

### 1.2 Certification **BSI Kitemark** (No. 684754).

The Halifax system is covered by third party certification. This provides confirmation that the system is fully compliant with the BS EN877 standard.

Although third party certification is not required by law, ongoing assessment and observations by an accredited certification organisation should give the customer confidence in our product.

In accordance with annex ZA of BS EN 877:1999+A1:2006, all Halifax products are CE marked and comply with the EU Construction Products Regulations (CPR 305-2011). All details relating to the CE marking can be found in the system Declarations of Performance which can be found at the end of this document.

BS EN 877: 2021 has a higher technical requirement for performance testing. Hargreaves Halifax Soil & Drain products have met and exceeded these requirements

*Copies of our certificate can be obtained by contacting [technical@hargreavesfoundry.co.uk](mailto:technical@hargreavesfoundry.co.uk)*



### 1.3 Professional Bodies

Hargreaves Foundry Drainage are members of the SoPHE (Society of Public Health Engineers) Industrial Group, part of CIBSE, the Chartered Institute of Building Service Engineers. SoPHE membership helps us ensure the Halifax Soil and Drain products are directly meeting the industry requirements.





## 1.4 Key Standards, Codes of Practice & Regulations

### **BS EN 877:1999 + A1:2006**

This harmonised European Standard applies to cast iron pipeline components used for the construction of discharge systems for buildings and for drains, normally as gravity systems. This standard specifies the requirements for the materials, dimensions, appearance and performance characteristics for cast iron pipes, fittings and accessories. It also covers quality assurance requirements for all products in the system.

### **BS EN 877:2021**

A development of the previous version, this standard is not Harmonised. HF are certified to both versions.

### **BS EN 752:2008**

Drain and sewer systems outside buildings

### **BS EN 12056-2:2000**

Gravity drainage systems inside buildings – sanitary pipework, layout and calculations

### **BS EN 12056-3:2000**

Gravity drainage systems inside buildings – roof drainage, layout and calculations

### **The Building Regulations 2010 (England and Wales) (as amended)**

- Requirement B3(4) – Internal fire spread (structure)
- Requirement E1 – Protection against sound from other parts of the building and adjoining buildings
- Requirement H1(1) – Foul water drainage
- Requirement H3(1) – Rainwater Drainage
- Regulation 7 – Materials and workmanship

### **The Building (Scotland) regulations 2004 (as amended)**

- Regulation 8(1)(2) – Durability, workmanship and fitness of materials
- Regulation 9 – Building standards applicable to construction
- Regulation 12 – Building standards applicable to conversions

### **The Building Regulations (Northern Ireland) 2012 (as amended)**

- Regulation 23(a)(i)(iii)(b)(i) – Fitness of materials and workmanship
- Regulation 35(4) – Internal fire spread – structure
- Regulation 49 – Protection against sound from other parts of the building and from adjoining buildings
- Regulation 51 – Reverberation in the common internal parts of a building containing flats or rooms for residential purposes • Regulation 79 – Drainage systems

## 1.5 Benefits of Halifax Soil & Drain systems

- Quiet in operation – Intrinsic sound-deadening properties of cast iron reduce acoustic insulation costs
- Fire resistant – As a material Cast Iron is non-combustible and has an A1 fire rating which reduces risk and removes the requirements for fire collars
- The paint finish has been tested and proven to offer high performance when exposed to aggressive substances

- Inherent strength and low maintenance requirements of cast iron combined with high quality surface coatings offer a fit and forget solution
- Correctly installed and maintained cast iron pipe systems can last in excess of 100 years
- Cost effective over the whole life of a building
- Extremely low waste at end of life – scrap castings can be fully re-cycled
- High pressure couplings designed for use in high-rise buildings
- The system can be easily modified and adapt to changes to the building in later life with minimal extra cost which helps keep the whole life costs down

## 1.6 Product Range

The Halifax Soil & Drain systems consist of a wide range of pipes and fittings of several diameters which are suitable for the majority of standard applications.

The products are available in diameters of **50mm – 300mm** and in each size, a selection of bends, branches, couplings, brackets and other assorted fittings are available

## 1.7 Responsible Production & Trading

### Sustainability & Recyclability

Cast iron is not only long-lasting but also **100% recyclable**. At the end of its lifecycle, our cast iron products can be fully recycled and reprocessed, helping to prevent waste from entering landfills. Where possible, we incorporate scrap cast iron into our manufacturing processes. A prime example of this recyclability is that all scrap iron generated during production is re-melted and reused thus reducing in-process waste. By choosing Halifax Drain products, you are selecting a pipe system that supports sustainability through recycling, efficient production, and resource conservation.

### Ethical Trading

*Hargreaves Foundry Drainage trade responsibly, our Corporate Social Responsibility Policy is available at [www.hargreavesfoundry.co.uk](http://www.hargreavesfoundry.co.uk)*

### Quality

The manufacturing site for our Halifax Soil & Drain system has been certified to ISO9001:2015 by the Beijing United Intelligence Certification Co. LTD., a UKAS certified organisation. The manufacturing site has also been audited by BSI as a mandatory part of the Kitemark process. This has also included all applicable type testing of the product range. This certification should give all of our customers the confidence that Halifax products are of a consistently high standard.

## 1.8 Ongoing Inspection & testing

All Halifax products are subject to ongoing inspection and testing to ensure that our high quality is both maintained and, where possible, improved. Samples of all deliveries are subject to dimensional, coating quality and chemical & physical properties tests to ensure that no deviation from the specification has been made. These ongoing tests are over and above the requirements from both of our certification bodies.



## 2. Reaction to Fire

### 2.1 Fire Rating Summary

The safety and comfort of a building's occupants should always get the highest priority on a construction project, especially on high rise buildings. To this end, both versions of the standard require mandatory fire testing by an approved 3rd party be carried out on the system. All tests carried out for this purpose must be in accordance with BS EN13501, EN1716 and BS EN13823

Material Fire ratings are based on a European classification system dependent upon the ignitability of the material, rate of smoke generation and likelihood of burning droplets or particles being released.

It is important to note that based upon this classification system, Cast Iron has an A1 fire rating, meaning that it is non-combustible and will not contribute at any stage to the fire. For descriptions of the fire rating definitions, please see Section 2.2 of this document.



#### Halifax Soil - A1

As a development on the previous version of the standard, BS EN 877:2021 includes provision for all possible fire classifications including A1. In recent re-testing of the Halifax Soil system by SGS, a Classification of **A1** was attained indicating that there is no contribution to fire.

#### Halifax Drain - A2-S1, d0

The requirements for below ground products to have increased resistance to chemical attack means that the Halifax Drain products have thicker coatings than those in the Halifax Soil range. This increased paint thickness means that the coating forms a larger proportion of the whole product which results in it being a more significant contribution to a fire but remains 'low risk'. As a result of the increased coatings, the Halifax Drain products have a rating of **A2-S1, d0**. The definitions for each fire classification are shown on the following page.

#### Steel Couplings

Our Stainless-Steel couplings have been independently fire tested by MPA NRW in Dortmund, Germany. The results of these tests showed that, when used to join Cast Iron pipes conforming to EN877, they achieved a rating of F90. This is a German rating and is not related to the ratings in Section 2.2. This rating means that the product will survive in a fire for 90 minutes before it fails.

## 2.2 Definitions

This table contains details of the main fire classifications. The details for sub-classes can be found below the table.

Classification	Performance Description
A1	No contribution to fire
A2	No significant contribution to fire
B	Very limited contribution to fire
C	Limited contribution to fire
D	Contribution to fire
E	Significant contribution to fire
F	Not tested / No performance requirements

### Additional classification for smoke protection

Classification	Performance Description
S1	May emit a very limited amount of smoke
S2	May emit a limited amount of smoke
S3	No requirement of restricted emission of smoke

### Additional classification for flaming droplets / particles

Classification	Performance Description
d0	No flaming droplets or particles are emitted
d1	Burning droplets or particles may be released
d2	No limitation on burning droplets or particles



## 3. Acoustic Performance

It is desirable to reduce the ambient noise in any structure and especially so in hospitals, hotels, schools etc. As noted in Annex F of BS EN 877, cast iron has excellent sound insulating properties due to its material density.

This intrinsic property sets the bar high above some other materials, particularly HDPE and other plastics. EN 14366 sets out a standard testing system for the acoustic properties of waste water pipes and provides a framework under which comparisons can be made with other tests made under the same conditions.



Hargreaves Foundry employed the Fraunhofer Institute for Building Physics (IBP) in Stuttgart to conduct these tests on the Halifax Soil & Drain systems on our behalf. These tests were undertaken as specified in EN14366 and were also related to IBP's own guidelines as released in June 2016.

### 3.1 Fraunhofer IBP Guidelines

IBP's "**Guidelines on the testing of the acoustic performance of wastewater systems according to DIN EN 14366**" were produced in order to ensure "*a high degree of reproducibility and comparability of the measurement results of different wastewater systems, as well as the applicability of the results in practice.*" There are several points in this document which are worthy of note.

In the first instance, some reports published prior to 2014, may no longer be supported by the Institute. The reasoning behind this decision was that some installations were made by the client rather than by the IBP technicians which introduced a variable with the result that "*the measurement values do not have any practical relevance anymore.*"

Secondly, **as of 2009, results measured below 10dB are no longer mentioned in the test reports.** This is due to several factors. There is an increased measurement uncertainty in the lower values which IBP deem to be unacceptable. The key fact however is that even if the instruments at IBP were able to reliably record readings this low, the results would not be noticeable under normal living conditions. As a general guide, please see section 3.4 for a comparative reference table.

### 3.2 Noise Transmission

Whilst the material properties of cast iron reduce the amplitude of the noise generated by waste water, it does not completely insulate against any noise generated. What noise is not deadened by the material density is transmitted via one of two mediums:

### Airborne Noise

This is sound waves transmitted by the air surrounding the pipe system and would be of particular importance in areas where the pipework is unshrouded such as car parks and shopping centres. The principle form of acoustic insulation in these instances would be the cast iron itself.

### Structure-borne noise

This is sound waves transmitted through the solid structure which supports the pipe system and is the easiest to reduce. The testing undertaken at Fraunhofer IBP focussed on the reduction of structure-borne noises by a variety of methods. It should be noted that structureborne vibrations have the greatest potential for disturbing the occupants of a building as they can be transmitted to any location in the building. Therefore, if noise reduction is a major consideration within a project, acoustic insulation of drainage and waste water systems should be considered.

### 3.3 Testing

All testing was conducted in accordance with EN 14366. Tests were also conducted in accordance with DIN 4109 and VDI 4100. The results obtained from each of these tests were comparable. All products tested are of the 100mm diameter and the flow rates used in the test are specified within EN 14366. Higher flow rates are unlikely to be encountered in normal use.

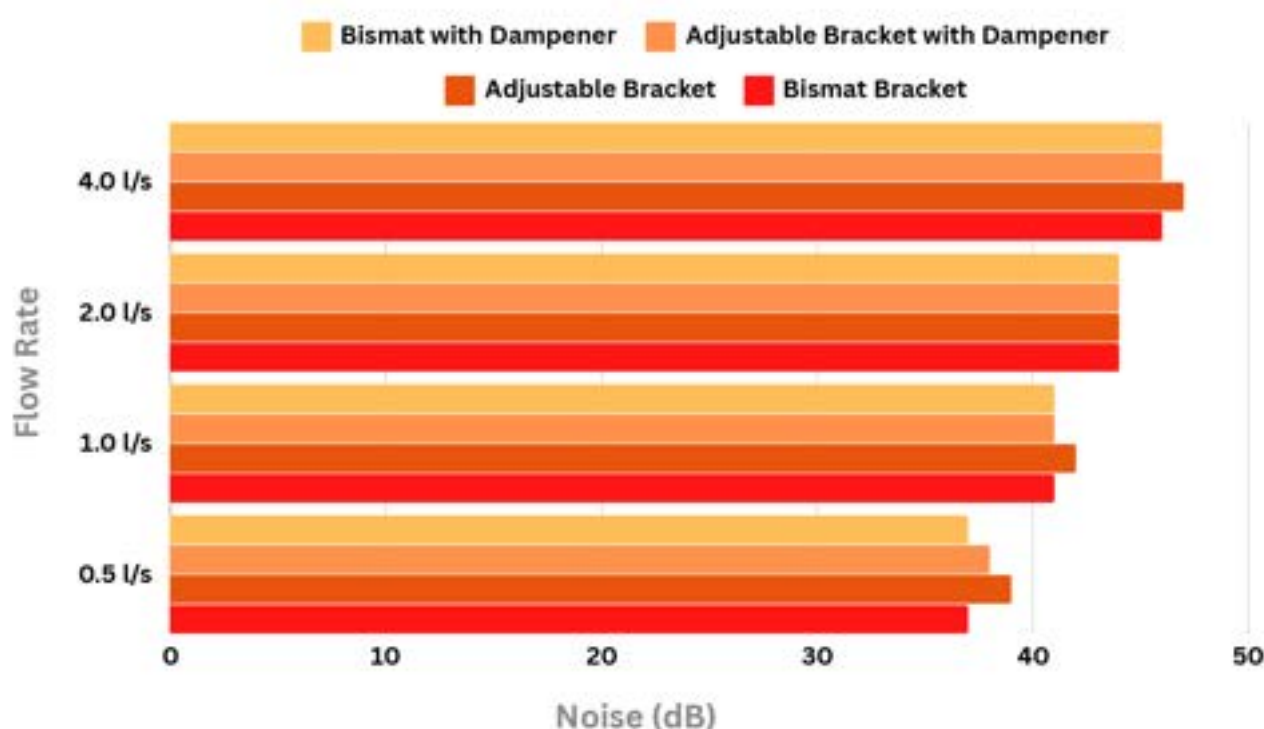

### Airborne

As could probably be predicted, the readings recorded for airborne noise transmissions were not generally reliant on the type of bracket used and tended to increase in amplitude with an increase in flow. As a point of reference, please see the comparative scale below.



**Structure-borne**

Due to the way that structure-borne noise is transmitted, the brackets have a greater impact upon the amplitude. The data table and graph here show a marked difference between the different bracket options tested and indicated that using the dampener (Part No. HSD6703) in conjunction with the Bismat bracket has an obvious impact on the amount of noise transmitted

It is important to note however that in order to achieve the greatest change, the bracket must be installed correctly as specified by Hargreaves Foundry. Failure to implement the installation correctly can result in sound levels varying by up to 15 dB(A).

Flow Rate	Bismat	Adjustable Bracket	Adjustable Bracket with Dampener	Bismat with Dampener*
0.5 l/s	14	21	< 10	< 10
1.0 l/s	17	24	13	< 10
2.0 l/s	21	27	17	13
4.0 l/s	25	31	21	18

*\*Grey Column must be used in conjunction with stack support brackets*

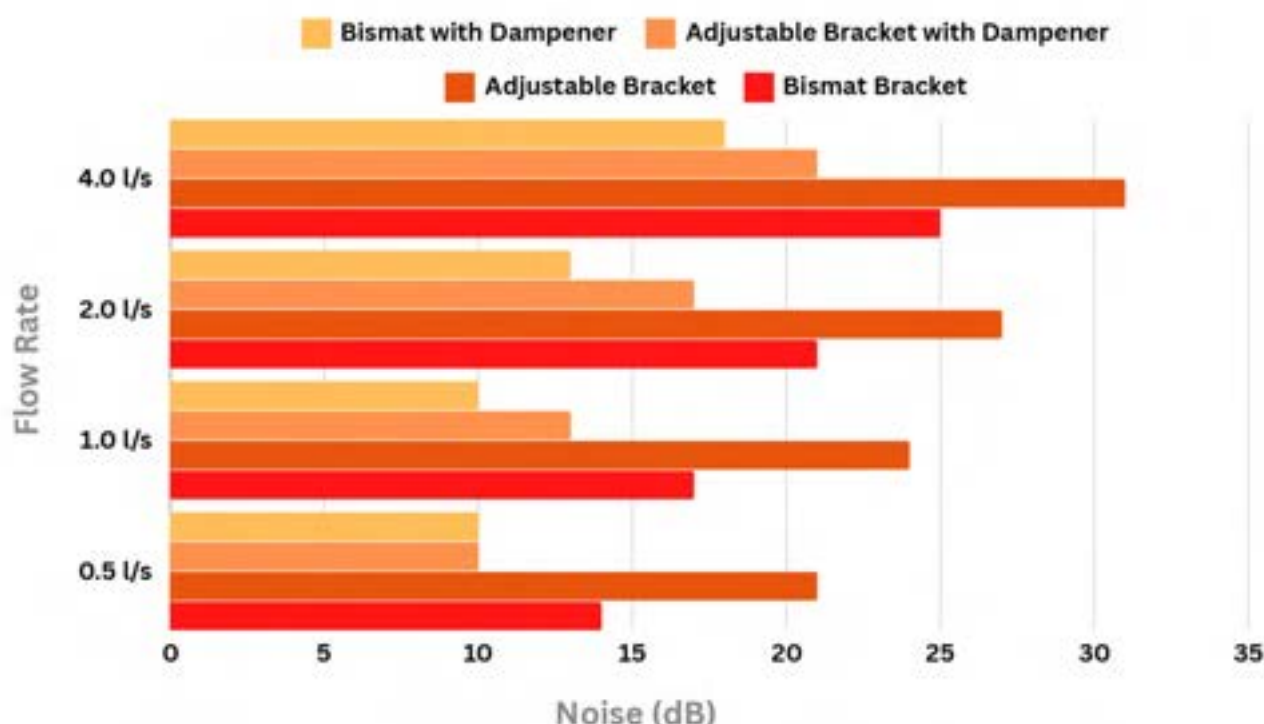

## 4. Dimensional & Mechanical Properties

### 4.1 Products Dimensions

#### 4.1.1 Diameters and Tolerances

The dimensions & tolerances for all products in the Halifax Soil & Drain range are shown in Table 4a (below) which have been extracted from EN877:1999 + A1:2006 Section 4.2.2 Table 1. All dimensions shown are in mm. By controlling the tolerance of the diameter, it is also possible to ensure that no product has excessive distortion of its shape. This will ensure an optimum fit when installed as part of a system.

DN	External Diameter DE		Wall Thickness	
	Nominal Value	Tolerance	Nominal Value	Min Value
50	58	+2 / -1	3.5	3.0
70	78	+2 / -1	3.5	3.0
100	110	+2 / -1	3.5	3.0
150	160	+2 / -2	4.0	3.5
200	210	+2.5 / -2.5	5.0	4.0
250	274	+2.5 / -2.5	5.5	4.5
300	326	+2.5 / -2.5	6	5.0

Table 4a. - Dimensions of Pipes & Fittings (mm)

#### 4.1.2 Pipes

Pipes for both Halifax Soil & Halifax Drain are only available in 3m lengths. Cast Iron has greater tolerance to movement in the surrounding ground than clay pipes which reduces the need for replacements. Due to the uniformity of the pipes, they can be cut at any point to allow for differences in the project's requirements while still being able to form a good seal with a coupling.

#### 4.1.3 Fittings

A Wide selection of fittings are available in both the above ground (Halifax Soil) and below ground (Halifax Drain) ranges, which should cater to the majority of pipe system requirements for the given diameters. Irrespective of the shape and size of the fittings, they have been specially designed to allow connection to the pipes via one of the available, specialised Halifax couplings.



## 4.2 Physical Attributes of Cast Iron

Cast Iron products enjoy a reputation for longevity of service with minimal maintenance requirements. This durability and reliability make it the perfect material for use in the modern construction industry where sustainability and value for money have never been so important. While there will be some decay of the cast iron (oxidising) this will be a slow enough process that it will not affect the performance of the pipe system for the life of the building, provided the system is installed and maintained correctly. Research completed by Weather Works Ltd in 2008 demonstrated that the whole life costs for cast iron over a 100-year life cycle are only 35% of PVC and aluminium.

## 4.3 Pipe Weights

As a part of the standardisation of products, BS EN877 specifies that the mass of a product should not be less than 85% of the stated nominal mass of the product. This nominal mass must be stated in the manufacturer's catalogue. To ease planning for installation, loading and support, please see table 4b (below).

DN	Empty Pipe Weight (kg/m)	Full Pipe Weight (kg/m)
50	5.0	7.0
70	6.1	10.0
100	9.1	17.5
150	14.6	32.3
200	23.3	54.7
250	33.3	89.3
300	43.3	122.8

Table 4b. - Dimensions of Pipes & Fittings (mm)

## 4.4 Physical Properties from EN 877

In addition to the inherent properties of cast iron, the BS EN877 standard that Halifax Soil and Drain conforms to specifies a number of physical characteristics which must be met by all products in the system. We undertake regular testing on pipes, couplings, fitting



#### 4.4.1 Hardness

The hardness of a material refers to the ease with which it may be physically marked, manipulated or cut. The BS EN877 standard sets out a Maximum value to be obtained via the Brinell hardness test. Cast iron has a higher hardness than equivalent PVC or HDPE systems which means that Halifax Soil & Drain pipes are unlikely to suffer from accidental marking, cutting or indentations of the surface. However, with the right tools it can easily be cut on site to achieve different pipe lengths.

#### 4.4.2 Ring Crush Strength

The ring crush strength of a pipe determines the likelihood of it failing when under a perpendicular load. This is particularly important for buried systems which will not only be subject to the back-fill of the trench in which it is buried but will also be subject to the varying loads imposed by structures and traffic above them. Test results show that cast iron consistently surpasses the requirements of EN 877 and offers greater resistance to crushing than PVC and HDPE.



#### 4.4.3 Tensile Strength

Cast iron products are graded dependent upon the tensile strength of the constituent material. All pipes and fittings (with the exception of some brackets and couplings) within the Halifax Soil & Drain ranges are made from grey cast iron in accordance with BS EN 877. The results from the ongoing testing and assessment of Halifax products ensures that the tensile strength is never below the minimum required in BS EN 877. This gives Halifax Pipes a great advantage when compared with PVC or HDPE pipes, which generally have a material tensile strength in the range 20-40% of the cast iron used in the Halifax Soil & Drain systems.

#### 4.4.4 Thermal Expansion

The expansion coefficient of Cast iron is approx. 0.01mm/m/°C. The material will expand by 0.01mm for every metre of the casting with every degree centigrade that the temperature increases.

This small amount is actually very similar to the coefficient of concrete and steel. The result of which is that when Halifax Soil & Drain products are installed in a building, they will not move relative to the structure around them. **This means expansion joints are normally not required, unlike HDPE and other plastic systems where expansion can be between 5 to 20 times greater than cast iron.**

### 4.5 Pipe Gradients & Filling Capacities

The below values have been calculated based upon the nominal values of the Halifax Soil & Drain pipes:



Filling degree 50% (h/d = 0.5)

Pipe DN	50		70		100		150		200		250		300	
	Q	V	Q	V	Q	V	Q	V	Q	V	Q	V	Q	V
cm/m	L/s	m/s	L/s	m/s	L/s	m/s	L/s	m/s	L/s	m/s	L/s	m/s	L/s	m/s
0.50	0.3	0.3	0.7	0.4	1.8	0.5	5.4	0.6	11.6	0.7	19.7	0.8	32.0	1.0
0.75	0.4	0.4	0.9	0.4	2.2	0.6	6.6	0.7	14.2	0.9	24.1	1.0	39.1	1.2
1.00	0.4	0.4	1.0	0.5	2.6	0.7	7.6	0.9	16.4	1.0	27.8	1.2	45.2	1.3
1.25	0.5	0.5	1.1	0.6	2.9	0.7	8.5	1.0	18.3	1.2	31.1	1.3	50.5	1.5
1.50	0.5	0.5	1.2	0.6	3.2	0.8	9.3	1.1	20.1	1.3	34.0	1.5	55.4	1.6
1.75	0.5	0.5	1.3	0.7	3.4	0.9	10.1	1.1	21.7	1.4	36.8	1.6	59.8	1.8
2.00	0.6	0.6	1.4	0.7	3.7	0.9	10.8	1.2	23.2	1.5	39.3	1.7	63.9	1.9
2.25	0.6	0.6	1.5	0.8	3.9	1.0	11.4	1.3	24.6	1.6	41.7	1.8	67.8	2.0
2.50	0.6	0.7	1.6	0.8	4.1	1.0	12.0	1.4	25.9	1.7	44.0	1.9	71.5	2.1
2.75	0.7	0.7	1.7	0.9	4.3	1.1	12.6	1.4	27.2	1.7	46.1	2.0	75.0	2.2
3.00	0.7	0.7	1.7	0.9	4.5	1.1	13.2	1.5	28.4	1.8	48.1	2.1	78.3	2.3
3.25	0.7	0.7	1.8	0.9	4.7	1.2	13.7	1.6	29.6	1.9	50.1	2.1	81.5	2.4
3.50	0.8	0.8	1.9	1.0	4.8	1.2	14.2	1.6	30.7	2.0	52.0	2.2	84.6	2.5
3.75	0.8	0.8	1.9	1.0	5.0	1.3	14.7	1.7	31.8	2.0	53.8	2.3	87.5	2.6
4.00	0.8	0.8	2.0	1.0	5.2	1.3	15.2	1.7	32.9	2.1	55.6	2.4	90.4	2.7
4.25	0.8	0.9	2.1	1.1	5.3	1.4	15.7	1.8	33.8	2.2	57.3	2.5	93.2	2.8
4.50	0.9	0.9	2.1	1.1	5.6	1.4	16.2	1.8	34.8	2.2	59.0	2.5	95.9	2.9
4.75	0.9	0.9	2.2	1.1	5.6	1.4	16.6	1.9	35.7	2.3	60.6	2.6	98.5	2.9
5.00	0.9	0.9	2.2	1.2	5.8	1.5	17.0	1.9	36.7	2.3	62.2	2.7	101	3.0



Q = FLOW RATE V = FLOW VELOCITY



Table 4c - Flow rate of pipes at 50% capacity

Filling degree 70% (h/d = 0.7)

Pipe DN	50		70		100		150		200		250		300	
	Q	V	Q	V	Q	V	Q	V	Q	V	Q	V	Q	V
cm/m	L/s	m/s	L/s	m/s	L/s	m/s	L/s	m/s	L/s	m/s	L/s	m/s	L/s	m/s
0.50	0.5	0.3	1.2	0.4	3.1	0.5	9.0	0.7	19.4	0.8	30.4	0.9	49.4	1.1
0.75	0.6	0.4	1.4	0.5	3.7	0.6	11.0	0.8	23.8	1.0	37.3	1.1	60.5	1.3
1.00	0.7	0.5	1.7	0.6	4.3	0.7	12.8	1.0	27.5	1.2	43.0	1.3	69.9	1.5
1.25	0.8	0.5	1.9	0.6	4.8	0.8	14.3	1.1	30.7	1.3	48.1	1.5	78.1	1.7
1.50	0.8	0.6	2.0	0.7	5.3	0.9	15.6	1.2	33.6	1.4	52.7	1.6	85.5	1.8
1.75	0.9	0.6	2.2	0.8	5.7	1.0	16.9	1.3	36.3	1.5	56.9	1.7	92.4	2.0
2.00	1.0	0.7	2.4	0.8	6.1	1.0	18.0	1.4	38.8	1.7	60.8	1.9	98.8	2.1
2.25	1.0	0.7	2.5	0.9	6.5	1.1	19.1	1.4	41.2	1.8	64.5	2.0	104.8	2.2
2.50	1.1	0.7	2.6	0.9	6.8	1.2	20.2	1.5	43.4	1.8	68.0	2.1	110.4	2.3
2.75	1.1	0.8	2.8	1.0	7.2	1.2	21.1	1.6	45.5	1.9	71.3	2.2	115.8	2.5
3.00	1.2	0.8	2.9	1.0	7.5	1.3	22.1	1.7	47.6	2.0	74.5	2.3	121	2.6
3.25	1.2	0.8	3.0	1.0	7.8	1.3	23.0	1.7	49.5	2.1	77.6	2.4	125.9	2.7
3.50	1.3	0.9	3.1	1.1	8.1	1.4	23.9	1.8	51.4	2.2	80.5	2.5	130.7	2.8
3.75	1.3	0.9	3.2	1.1	8.4	1.4	24.7	1.9	53.2	2.3	83.3	2.5	135.3	2.9
4.00	1.4	0.9	3.3	1.2	8.7	1.5	25.5	1.9	54.9	2.3	86.0	2.6	139.7	3.0
4.25	1.4	1.0	3.4	1.2	8.9	1.5	26.3	2.0	56.6	2.4	88.7	2.7	144	3.1
4.50	1.4	1.0	3.5	1.2	9.2	1.6	27.1	2.0	58.3	2.5	91.3	2.8	148.2	3.1
4.75	1.5	1.0	3.6	1.3	9.4	1.6	27.8	2.1	59.9	2.5	93.8	2.9	152.2	3.2
5.00	1.5	1.0	3.7	1.3	9.7	1.6	28.5	2.2	61.4	2.6	96.2	2.9	156.2	3.3

Q = FLOW RATE V = FLOW VELOCITY

Table 4c - Flow rate of pipes at 70% capacity





Filling degree 100% (h/d = 1.0)

Pipe DN	50		70		100		150		200		250		300	
	Q	V	Q	V	Q	V	Q	V	Q	V	Q	V	Q	V
Slope e/j	Q	V	Q	V	Q	V	Q	V	Q	V	Q	V	Q	V
cm/m	L/s	m/s	L/s	m/s	L/s	m/s	L/s	m/s	L/s	m/s	L/s	m/s	L/s	m/s
0.50	0.6	0.3	1.4	0.4	3.7	0.5	10.8	0.6	23.2	0.7	39.3	0.8	64	1.0
0.75	0.7	0.4	1.7	0.4	4.5	0.6	13.2	0.7	28.4	0.9	48.1	1.0	78.3	1.2
1.00	0.8	0.4	2.0	0.5	5.2	0.7	15.2	0.9	32.8	1.0	55.6	1.2	90.4	1.3
1.25	0.9	0.5	2.2	0.6	5.8	0.7	17.0	1.0	36.7	1.2	62.2	1.3	101.1	1.5
1.50	1	0.5	2.4	0.6	6.3	0.8	18.7	1.1	40.2	1.3	68.1	1.5	110.7	1.6
1.75	1.1	0.5	2.6	0.7	6.8	0.9	20.2	1.1	43.4	1.4	73.5	1.6	119.6	1.8
2.00	1.2	0.6	2.8	0.7	7.3	0.9	21.5	1.2	46.4	1.5	78.6	1.7	127.8	1.9
2.25	1.2	0.6	3.0	0.8	7.8	1.0	22.8	1.3	49.2	1.6	83.4	1.8	135.6	2.0
2.50	1.3	0.7	3.2	0.8	8.2	1.0	24.1	1.4	51.9	1.7	87.9	1.9	142.9	2.1
2.75	1.3	0.7	3.3	0.9	8.6	1.1	25.3	1.4	54.4	1.7	92.2	2.0	149.9	2.2
3.00	1.4	0.7	3.5	0.9	8.9	1.1	26.4	1.5	56.8	1.8	96.3	2.1	156.6	2.3
3.25	1.5	0.7	3.6	0.9	9.3	1.2	27.5	1.6	59.1	1.9	100.2	2.1	163.0	2.4
3.50	1.5	0.8	3.7	1.0	9.7	1.2	28.5	1.6	61.4	2.0	104	2.2	169.1	2.5
3.75	1.6	0.8	3.9	1.0	10.0	1.3	29.5	1.7	63.5	2.0	107.7	2.3	175.1	2.6
4.00	1.6	0.8	4.0	1.0	10.3	1.3	30.5	1.7	65.6	2.1	111.2	2.4	180.8	2.7
4.25	1.7	0.9	4.1	1.1	10.7	1.4	31.4	1.8	67.6	2.2	114.6	2.5	186.4	2.8
4.50	1.7	0.9	4.2	1.1	11.0	1.4	32.3	1.8	69.6	2.2	117.9	2.5	191.8	2.9
4.75	1.8	0.9	4.4	1.1	11.3	1.4	33.2	1.9	71.5	2.3	121.2	2.6	197	2.9
5.00	1.8	0.9	4.5	1.2	11.6	1.5	34.1	1.9	73.4	2.3	124.3	2.7	202.1	3.0

Q = FLOW RATE V = FLOW VELOCITY



Table 4c - Flow rate of pipes at 100% capacity





## 5. Product Coatings & Appearance

### 5.1 Halifax Soil Pipes

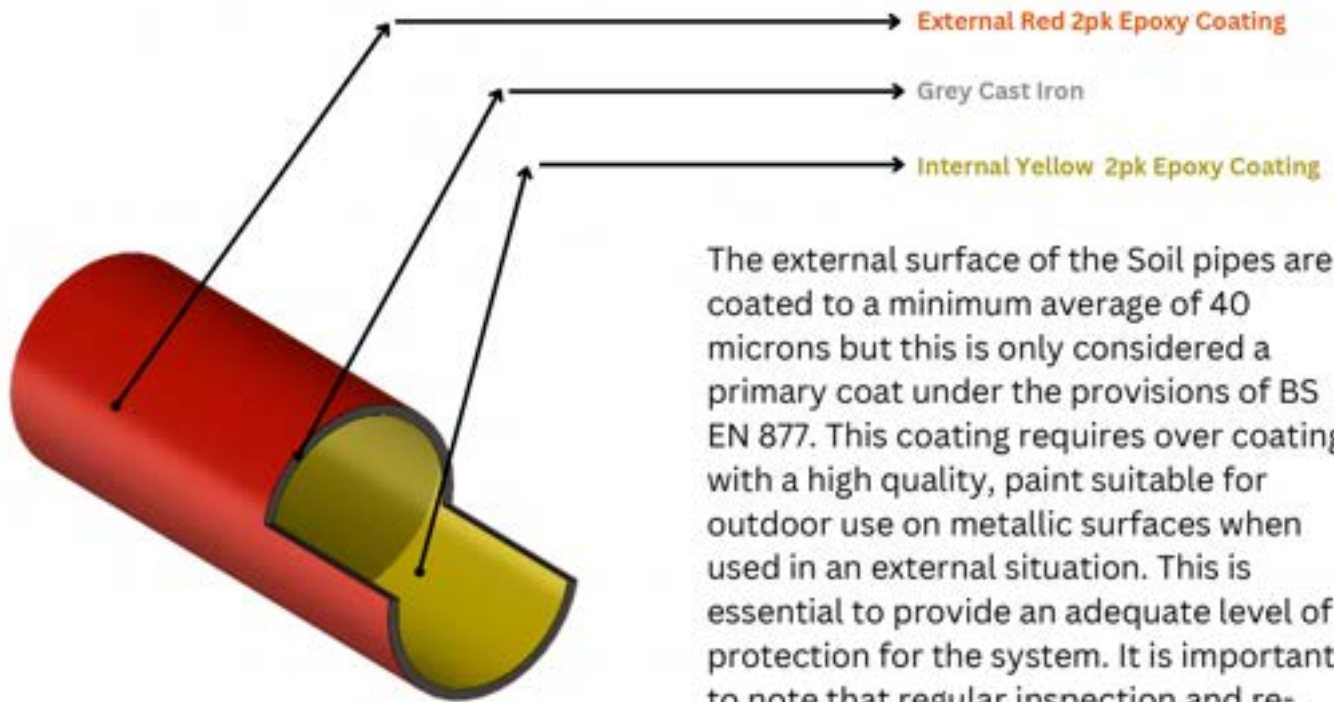

The external surface of the Soil pipes are coated to a minimum average of 40 microns but this is only considered a primary coat under the provisions of BS EN 877. This coating requires over coating with a high quality, paint suitable for outdoor use on metallic surfaces when used in an external situation. This is essential to provide an adequate level of protection for the system. It is important to note that regular inspection and re-coating of the products may be necessary.

The external surface of the Soil pipes are coated to a minimum average of 40 microns but this is only considered a primary coat under the provisions of BS EN 877. This coating requires over coating with a high quality, paint suitable for outdoor use on metallic surfaces when used in an external situation. This is essential to provide an adequate level of protection for the system. It is important to note that regular inspection and re-coating of the products may be necessary.

### 5.2 Halifax Soil Fittings

Halifax Soil fittings are finished internally and externally with a minimum average 70 microns of red 2-pack epoxy paint. This paint has passed the same rigorous testing to which the pipes have been subjected including a 24 Hr hot water test at 95°C, material hardness tests, tensile tests and a 1500 cycles water temperature test between 15°C and 93°C

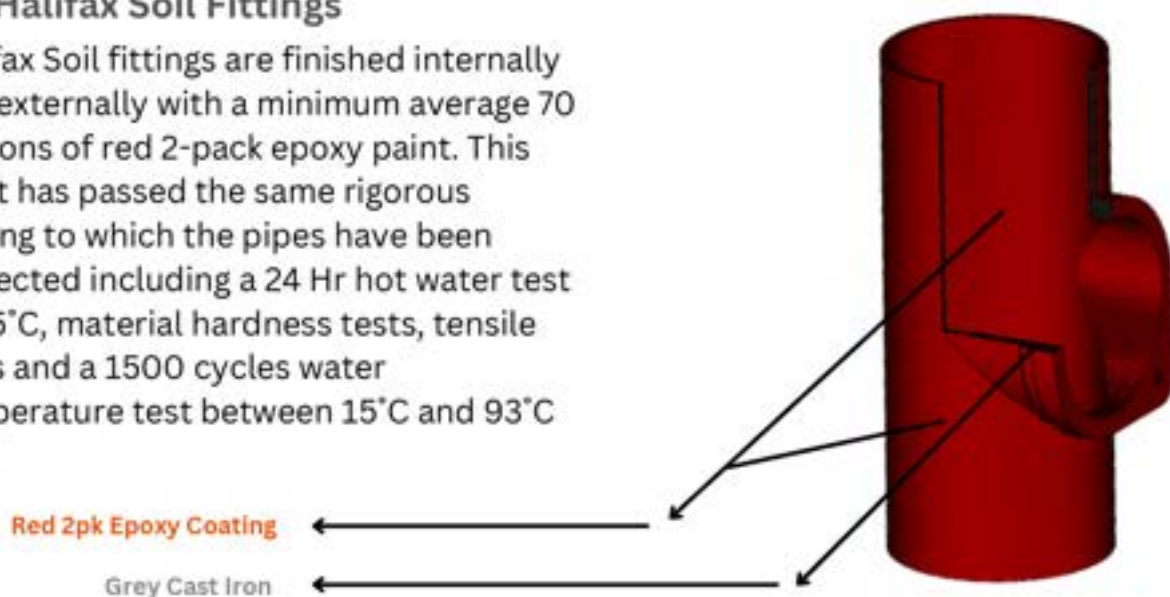

### 5.3 Halifax Drain Pipes

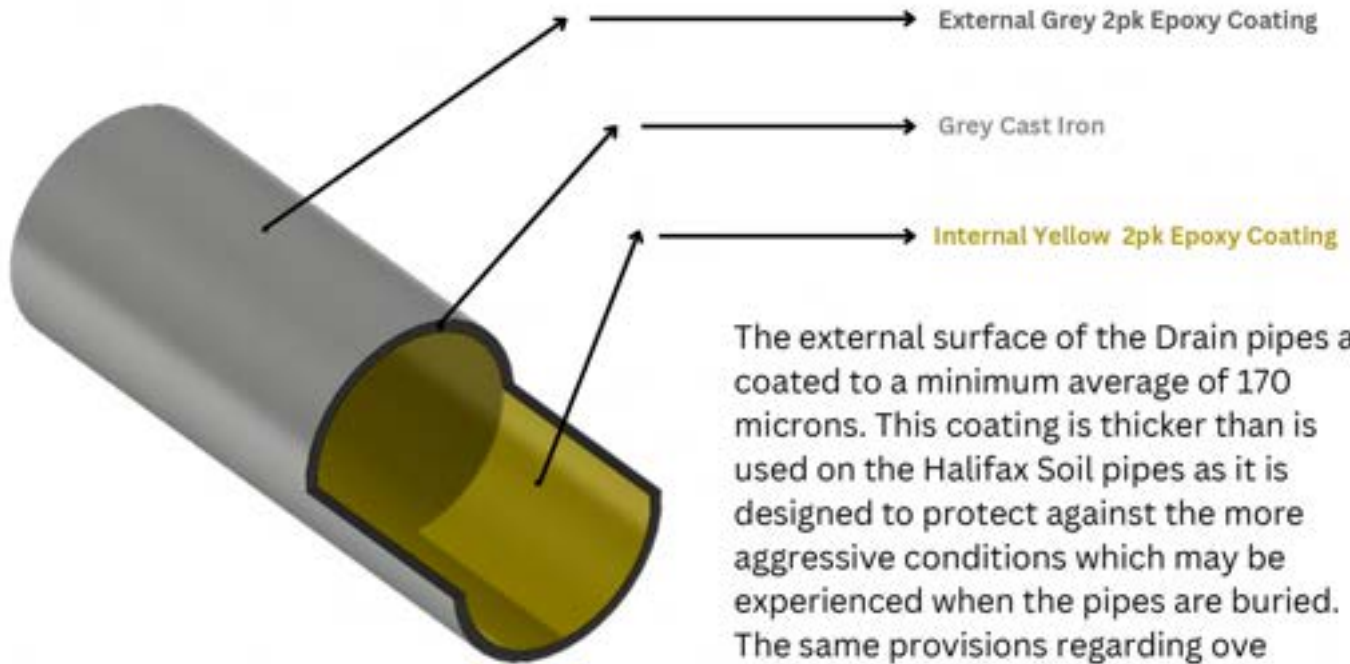

The external surface of the Drain pipes are coated to a minimum average of 170 microns. This coating is thicker than is used on the Halifax Soil pipes as it is designed to protect against the more aggressive conditions which may be experienced when the pipes are buried. The same provisions regarding ove

The internal surface has a minimum average coating thickness of 130 microns. This enables the Halifax Drain pipes to withstand a variety of tests designed to reproduce the conditions that the products will encounter in their working life. This includes a 30-day waste water test at 23°C, a 30-day chemical resistance test at both PH 2 and PH 12 and a 1500 cycles water temperature test between 15°C and 93°C.

### 5.4 Halifax Drain Fittings

Halifax Drain fittings are finished externally with a minimum average of 150 microns of grey 2-pack epoxy paint. The increase in paint thickness over the Halifax Soil is due to the more stringent requirements for external coating performance for below ground products

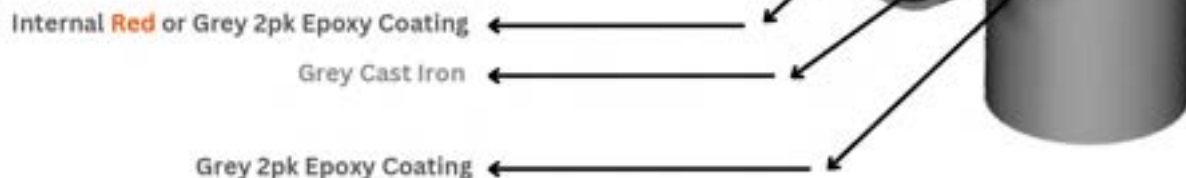

The Halifax Drain fittings are coated internally with either red or grey 2-pack epoxy to a minimum average thickness of 150 microns. This paint has also been subjected to the same stringent testing regime as the other components of the system. These tests include a 350-hour salt-spray test, a 30-day waste water test at 23°C and a series of dimensional checks



## 5.5 Chemical Resistance of Coatings

The Halifax Soil & Drain system is designed for use in commercial and residential properties and is resistant to attack by chemicals between PH2 and PH12 which have been diluted by ordinary tap water. Unfortunately, as cleaning agents are developed, they are becoming more aggressive and as such are causing more damage to drainage systems than comparable products will have done a number of years ago. It is also important to note that other substances can cause an equal or greater level of harm to both the system and the environment.

### What is being disposed of down the sink and drain?

Four things you should never put down the drain:

- Toxic chemicals like paint, cleaning products, oil, and solvents. ...
- Medications. ...
- Grease, fats, and oils. ...
- Putting milk (or any other dairy products for that matter) down the drain can have serious environmental consequences. So serious in fact, that UK businesses can actually be fined for doing it. This is because milk requires large quantities of oxygen to be broken down into the environment, depriving other organisms of the air they need to survive.

The biggest issue facing soil and drainage systems is what is being discharged from households, commercial and industrial premises. The most common are surfactants and soaps associated with cleaning agents and detergents to highly concentrated acidic and alkaline solutions, which may feed into the waste water system. These cleaning agents and aggressive chemicals are used in a wide variety of products, from detergents, disinfectants, oven cleaners, and chemicals for unblocking sinks.

One of the most problematic of these are the "drain" unblocking chemicals which can be either acidic (sulphuric acid) or alkaline (sodium hydroxide). Older pipes and those made of polyvinyl chloride (PVC) are more susceptible to damage from drain cleaners. The usage of these chemicals is not always controlled by the householder, commercial or industrial premises, and therefore there is a potential, albeit unintentionally, that less dilution would be used. See the H&S Note on "Drain Cleaning" solutions on the next page. In addition, some cleaning products rely on heat to increase their effectiveness in removing stains, grease etc, therefore these effluents could be discharged from properties with temperatures in the range 15°C to 45°C.

All hospitals and University Research and teaching / wet Laboratories have very strict guidelines on what can and can't be put down sink and drains; it should be noted that undiluted blood should not be used to "drain" via cast iron. Cast Iron can only be used when a dilution trap is used in some "wet labs". Otherwise, Glass, Vulcathene, Geberit or other drainage products should be used. Outside of "wet labs" the Halifax Soil and Drain system coatings are more than adequate when used in these environments.



**Here is a list of some the most common used cleaning products and their pH levels:**

- Chlorine bleach (pH 11-13): At the top of the alkaline level, therefore corrosive and to be used with caution and not on all surfaces, as these can be damaged.
- Oven cleaner (pH 11-13): The same as bleach, so ideal to cut through grease and grime, but protect the kitchen floor and worktop when using it as they could be damaged.
- Washing up liquid (pH 7-8): The neutrality makes this cleaning product ideal for daily cleaning. Most surfaces will not be damaged, and it can be used in hundred places around the house, not only to do the washing up.
- Toilet bowl cleaner (pH 1-3): Very acidic product, so ideal to remove minerals and other non-organic substances. As it is at the end of the pH scale, you have to be careful when using it.

**Here is a list of other common items and their pH levels:**

- Vinegar (pH 3): As a natural product, most would think vinegar is safe to use almost everywhere in the house, but it is not the case. Vinegar is quite acidic so it can damage some delicate surfaces (e.g. wood or limestone). On the other hand, it is great for removing mineral deposits (e.g. lime scale).
- Cherry Coke and Coca-Cola have a pH of 2.5, comparable to some toilet cleaners!!

**H&S Note on “Drain Cleaning” solutions**

Individuals may unknowingly mix two different types of drain cleaners, without being fully aware of the potential health and safety risks.

For example, the neutralization reaction of the acid and base may seem harmless, but in reality, this reaction is extremely exothermic; and the mixing of acid drain cleaners and bleach can result in the generation of chlorine gas.

One product that is used by commercial cleaners is “One Stop” (contains 90% Sulphuric Acid), this product is extremely corrosive and has been known to chemically erode away the walls of cast iron drain pipes and fittings whilst dissolving away a blockage in the drain system; this can lead to failure and subsequent, expensive replacements.

The first thing to know is what your pipes are made of. Many drain cleaners utilize extremely caustic chemicals in order to take care of truly tough stuff like hair and grease. Note: You should not use a strong, caustic chemical(s) when you have stainless steel, galvanized steel, aluminium, or copper piping.

The internal paint coating used on our Halifax Soil and Drainage system have been developed to meet the requirements of EN877, which requires, coatings to withstand temperatures of 95°C, cyclic temperatures from 15°C - 93°C, waste water @ 23°C, and chemical resistance from pH 2 (Sulphuric Acid) – pH 12 (Sodium Hydroxide); and as such, our coatings can handle an array of chemicals and pH values (within the tested range) found in most waste water.



5.6 Product Markings

Pipes

The markings are painted onto the external surface of the pipes using a stencil and are located 1 per metre length of the pipe. An example of the pipe markings can be seen here.

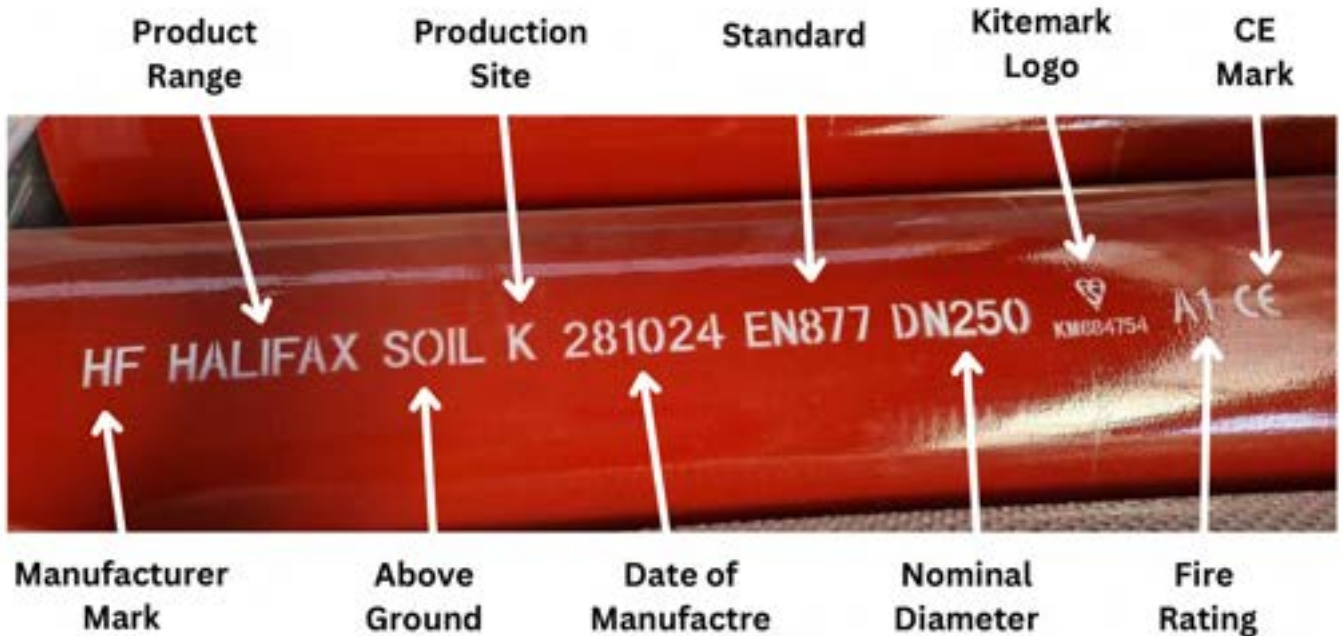

Fittings

Manufacturing and production details are cast on the product as stipulated by EN 877. Additional markings are applied in the form of sticky labels in order to ensure conformity with Annex ZA of EN877. These labels commonly contain: manufacturers logo, CE mark, Paint batch number and production date. An example of this can be seen here.

On Newer products, this will be replaced by the labels below:



### Ductile Iron Couplings & Gaskets

Manufacturing and production details are cast on the product as stipulated by EN 877 as shown here. Additional markings may be applied in the form of sticky labels in order to ensure conformity with Annex ZA of EN877. These labels are similar to those used on the fittings.

Gasket markings form part of the mould used to shape the rubber and are shown in the image below. Production date of gaskets is indicated by the mark in the respective quadrant of the cross.

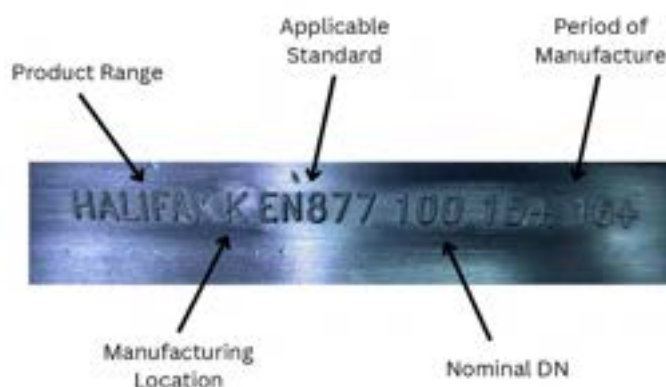
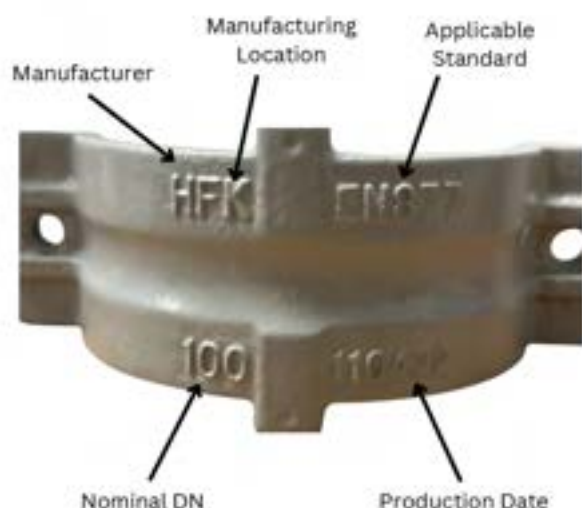

### 5.7 Buried Pipelines

While both pipe systems use the same 2-pack Epoxy coating, the coating used on the Halifax Drain system is thicker than that used on the Halifax Soil system and as such, has a higher resistance to chemical attack. This makes the Halifax Drain system more suited to being buried below ground. It should be noted however that where the products are to be placed in particularly aggressive soils (e.g. peat) where the PH value is less than 6, it is recommended that the pipe system be encased in polyethylene sleeves for additional protection

### 5.8 Concrete encasement

In a situation where the pipes need to be encased in concrete, provided the factory applied coating is intact & undamaged, it will form a barrier between the cast iron and the concrete therefore making either system suitable for use. However, due to the thicker coating mentioned above, the system is to be completely encased (as opposed to a short length passing through a concrete wall/foundation), the Halifax Drain system would be the most appropriate. In the event that the concrete encasement becomes damaged or is not fully coherent, the painted surface of the casting may be required to form a barrier between the otherwise exposed cast iron and any encroaching aggressive substances.



## 6. Couplings

### 6.1 Joint Tests

BS EN 877 recognises the importance of secure, leak-free joints and as such, has a requirement for all pipe systems to undergo joint testing. Halifax Soil and Drain products have undergone strict water and air tightness tests which proved that the couplings within the system, are capable of making sound seals with the pipes aligned, at 3°, and when subjected to shear forces. The system meets the requirement for gravity soil installations for both external & internal pressure resistance.

### 6.2 Ductile Iron Couplings

- Two-piece coupling manufactured from Ductile Iron BS EN 1563
- ZP / SS socket cap locking screw and nut M8 x 40 for 50mm to 100mm and M8 x 55 for 150mm to 300mm (6mm Allen drive)
- 2 locking screws on 50 – 100mm and 4 locking screws on 150mm to 300mm diameters
- EPDM sealing gasket
- See table below for test pressures
- Couplings in 2-part epoxy finish red/brown colour for above ground soil and grey colour for below ground drain
- Above ground unique grub screw system for electrical continuity
- Suitable for re-use (Gasket should be checked before re-installation for damage/distortion and replaced if necessary)



#### Test Pressures

As per Table 4, Clause 4.7.5 of BS EN877:2021

Test Condition	Hydrostatic Test Pressure (Bar)			
	DN ≤ DN200		DN > DN200	
	Internal	External	Internal	External
a). Aligned Joint	0 to 5	0 to 0.5	0 to 3	0 to 0.5
b). Deflected joint (3°)	0 to 5	-	0 to 3	-
c). Subject to Shear Force	0 to 1	-	0 to 1	-

### 6.3 Rapid Connect Coupling

These are not suitable for use below ground so are only available in the Halifax Soil range of products. The Halifax system uses the Rapid Connect steel coupling;

- Stainless steel body, bolts and nuts steel, surface protected
- Single screw lock, fast and reliable
- Resists axial pull forces of up to 0.5 bar
- M8 zinc plated socket cap screw for 50-150mm (6mm Allen Drive)
- M10 zinc plated socket cap screw for 200mm (8mm Allen Drive)
- Defined locking torque without using a special tool
- 6mm Allen drive • EPDM rubber sleeve
- Suitable for re-use



### 6.4 High Performance Coupling

Fully re-usable axial restraint pipe coupling system for use in high risk areas e.g. Computer suites etc. and also areas where a pipe stack flows through several floors without outlets.



- WRAS approved
- 16 bar internal pressure
- Casing 304 stainless steel no spot welding
- 2 locking screws on all sizes
- Alloy steel zinc PTFE coated
- EPDM gasket with stainless steel anchor teeth

### 6.5 Halifax Push Fit Coupling

- Single-piece casting manufactured from Ductile Iron BS EN 1563
- Two EPDM sealing gaskets
- Uses the same grub-screw continuity system as proven on our Ductile Iron Couplings
- Meets Hydrostatic test pressures as outlined in Table 4 (above)
- Couplings in 2-part epoxy finish to match the applicable system
- Suitable for re-use (Gasket should be checked before re-installation for damage/distortion and replaced if necessary)





## 6.6 Electrical Continuity

Electric continuity is needed when using metal pipes in construction to provide an earth. Cast iron has excellent conductive properties, however, the Halifax Soil system includes rubber gaskets where the adjacent pipe ends or fittings connect, that create a barrier to electrical conductivity.

The Halifax system has a choice of two standard couplings, the Rapid Connect coupling in stainless steel and the ductile iron coupling. Essentially, as the Rapid Connect coupling is tightened the edges are designed to 'cut' through the coating ensuring metal on metal contact. This maintains the conductive path allowing the electrical current to flow to earth.

To achieve the same result with a ductile iron coupling the Halifax system employs a unique grub screw feature. By tightening the two grub screws, one above and one below the joint, contact is made through the coating with the metal underneath and the continuity via coupling and grub screws is achieved.

Tests commissioned by Hargreaves Foundry at an independent laboratory (Pullmans Instruments Ltd) in accordance with section NA8 of BS EN 877:1999 + A1:2006 have shown that with a steady current of 25 Amps, both the Rapid Connect couplings and the Ductile iron couplings demonstrate conclusively excellent electrical continuity. When Halifax Soil couplings are correctly installed, they provide a resistance less than 4% of the maximum,  $0.3\Omega$ , permitted.

These results prove that the Halifax Soil system is suitable for use in structures where creating a continuous electrical discharging circuit is necessary.



Electrical Continuity Testing





## 7. Brackets

The Halifax Soil and Drain systems are designed to be used in a range of common situations. To aid with this flexibility, there are a range of brackets designed to suit different applications.

### 7.1 Support intervals

It is a requirement of BS EN 12056 code of practice that supports for a horizontal pipe run are no more than 3m apart. Hargreaves recommends that support is provided every 1.5m with the first bracket placed within 500mm of the first coupling. The pipe should also be supported at every change in direction or connection with another pipe. In the case of long pipe runs, it may be advisable to place lateral support every 12m. The maximum length for a single threaded rod to a bracket should be 750mm however longer drops may be utilised if two rods and a split band clip are used.

When the pipes are running vertically, the stack should be supported by a load bearing bracket at each floor level such as those listed below. The maximum separation between brackets should be 3m. It is important that each bracket is correctly secured as the installation progresses to avoid undue strain at the bottom of the stack. It is recommended that extra support is provided near fittings to ensure correct alignment of the stack.

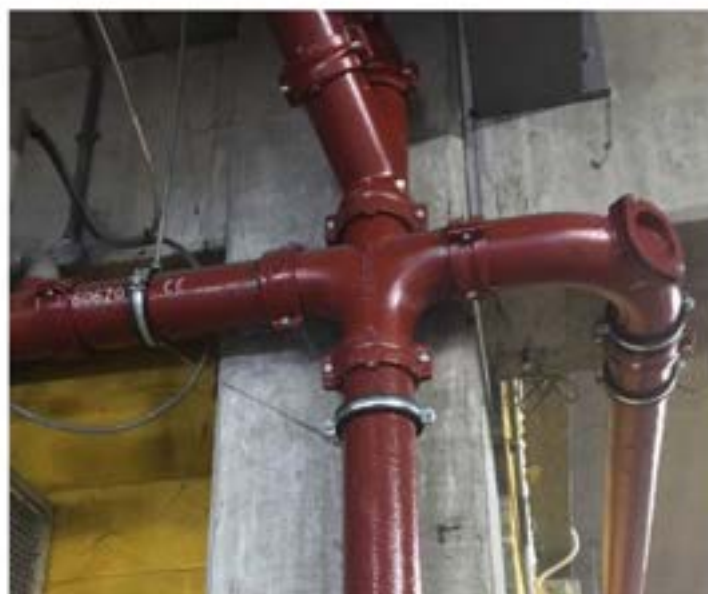



### 7.2 Coated Adjustable Brackets

These are supplied in steel or cast iron and are the simplest way to support a Halifax system. They are supplied coated in the same external finish as the Soil and Drain fittings so are a good choice for projects where the system will be on show and the support brackets are required to blend in with the remainder of the system. These brackets are supplied in two halves which are joined together with Nuts and Bolts. Fixing to the wall is achieved via the fixing slot on one half of the bracket. This fixing slot can be used with a variety of different products such as threaded rods, acoustic dampeners and standard bolts.



### 7.3 Rubber Lined Bismat bracket

These are supplied in steel or cast iron and are the simplest way to support a Halifax system. They are supplied coated in the same external finish as the Soil and Drain fittings so are a good choice for projects where the system will be on show and the support brackets are required to blend in with the remainder of the system. These brackets are supplied in two halves which are joined together with Nuts and Bolts. Fixing to the wall is achieved via the fixing slot on one half of the bracket. This fixing slot can be used with a variety of different products such as threaded rods, acoustic dampeners and standard bolts.



### 7.4 Heavy-Duty Bossed Brackets

This bracket is available in both a standard and EPDM rubber lined version. The bossed socket allows the pipe to be positioned at a distance from its supporting structure via the use of threaded rods. The threaded boss contains threads of two different diameters to give flexibility depending on what is required for a particular project. These brackets are manufactured in zinc plated steel to resist corrosion. The rubber on the lined version of this bracket is a similar design to that used on the Bismat brackets.



### 7.5 Stack Support Brackets

These are a ductile iron product designed for use with Halifax stack support pipes and cantilever arms. They are designed specifically to provide support and restraint for large vertical pipe systems. Hargreaves recommends that a stack support is placed every fifth floor from the base (where average floor height is 2.5m). For further information please see our installation guide (HFDS 108)



### 7.6 Acoustic Dampener

The acoustic dampener bracket (HSD6703) is designed for use with the Rubber-lined Bismat bracket. Although it is also compatible with the Coated Adjustable Bracket and the Heavy-duty bossed brackets, in testing, the combination of dampener and Bismat resulted in the lowest transmission of noise. More details regarding this bracket can be found in section 3 of this document.

To achieve the optimum effect, the bracket should be installed with a gap of 10mm between the wall and dampener and 16mm between the dampener and the Bismat.

### 7.7 Console Bracket

Used as an alternative to a stack support pipe, stack support bracket and 2 cantilever arms, this single unit provides an adjustable, fixing system for supporting pipe stacks. The console bracket is available for our 70, 100, 150 and 200mm pipes and the clamp provides all the benefits of the Bismat bracket while increasing the support provided.





## 8. Pipe System Design Guidance

### Excerpts & references from BS EN 12056-2:2012.

[ It should be noted that these requirements also form part of The Building Regulations 2010 – Document H (2015 Edition)]

When designing pipe systems for use in the UK, it is imperative that the requirements of the above standard and Building Regulations are adhered to. To this end, some key guidance notes are included here for reference purposes. For full details, BS EN 12056-2 should be consulted before a soil system design is finalised.

#### ND.3.2.4 – Branch pipe bends and junctions

*This section refers to the use of swept-radius branches*

Bends in branch discharge pipes should be avoided, especially for single and ranges of wash basins, as they can cause blockages and increase self-siphonage effects. When they are unavoidable, they should be of a large radius.

Junctions between branch discharge pipes of about the same diameter should be swept in the direction of flow using swept entry branches, with a 25mm minimum root radius, otherwise, 45° branches should be used. To minimise the risk of blockage, branches up to DN 40 size joining larger diameter horizontal branches of DN 100 or over should, if practicable, connect to the upper part of the pipe wall of the larger branch. For the same reason, opposed branch connection in the horizontal plane to a main branch discharge pipe should be avoided.

#### ND.3.5.2 – Bends at the base of stacks

Bends at the base of a discharge stack should be of large radius (minimum centre line radius 200mm) or two 45° radius bends may be used. Increasing the diameter of the bend at the base of a stack is an alternative but this may oversize the drain and be uneconomic.

#### ND.3.5.3 – Branches at the base of stacks

Generally, for systems up to five storeys, the distance between the lowest branch connections and the invert of the drain should be at least 750mm, but 450mm is adequate for low rise single dwellings. For larger multi-storey systems it is better to connect the ground floor appliances to their own stack or the horizontal drain and not directly to the main stack. For buildings over 20 storeys high, it may be necessary to connect both the ground and first floor appliances in the same manner.

#### ND.3.5.4 – Offsets

Offsets in the wet portion of a discharge stack should be avoided. When they have to be fitted, large radius bends should be used as described in ND.3.5.2. In a secondary ventilated stack system, connections to the discharge stack should be made above and below the offset. Offsets above the topmost appliance or branch connection do not require venting.

## 9. Connecting to Other Systems

### 9.1 Equivalent Systems

The range of Pipe bores in the Halifax Soil and Drain system is designed to be compatible with any number of equivalent systems. The standard couplings within the Halifax Soil and Drain systems are suitable for connecting products of other materials into the system provided the external diameters are the same. (For example: A Plastic pipe with an O/D of 110mm could be joined to the 100mm Halifax Drain pipe (HD4001) with a 100mm Halifax Drain Ductile Iron Coupling (HD4012) because the outer diameter is the same.)

### 9.2 Conventional Soil / Drain Systems

Halifax Soil and Drain are modern adaptations of a traditional Cast Iron waste system. Despite containing different jointing methods than would have originally been used, it is still possible to connect the new system into existing products using a traditional, caulked joint. This versatility allows the Halifax systems to be used where an upgrade is necessary thus saving money over alternative systems which would require a full replacement.

### 9.3 Threaded Connections

The Halifax Soil system threaded boss is designed to suit standard 2" BSPT threaded connections from plastic or copper pipe systems and provide a secure way of transitioning between smaller bore pipes of other materials. These bossed connections can operate either as blank ends, where the other system can join the start of the Halifax system or, on specially designed boss pipes, to allow the ingress of waste part way through a system. In both cases, the bossed fittings can be connected to the main system using standard Halifax Soil Couplings

### 9.4 Compression Fit Boss

There may be some occasions where using a threaded component to connect into the system is not practical. In this case, a compression-fit boss pipe may be more suitable for use. These can be used with any 50mm pipe which can simply be pushed home and then the bolts on the front plate, tightened to form a water-tight seal. These are available in single, double opposed and double 90° versions.







### 9.5 Manifold Connector

The Halifax Soil Manifold Connector provides a simplified solution for joining multiple waste sources with the main soil stack. The three insertion points cater to copper, plastic or similar material push-fit connections from 32 to 40mm Diameter. The rubber bungs included with the product allow the insertion points to be blanked off if they are not required thus providing a degree of versatility that will help the system to adapt to the user's requirements.

Connection to the main pipe stack is made by using any of the standard Halifax Soil 100mm couplings such as the Ductile Iron couplings (HS4012). The Halifax Soil Manifold connector has been designed in such a way that any incoming waste water will not unduly impede the flow within the main stack.

# HALIFAX SOIL



*Mechanically Jointed Cast Iron Systems*

## PRODUCT TABLES

*Fully Compliant with*

**BS EN 877:1999 + A1:2006**

**BS EN 877:2021**



**KM 684754**

**BS EN 877**



Double Spigot Pipes

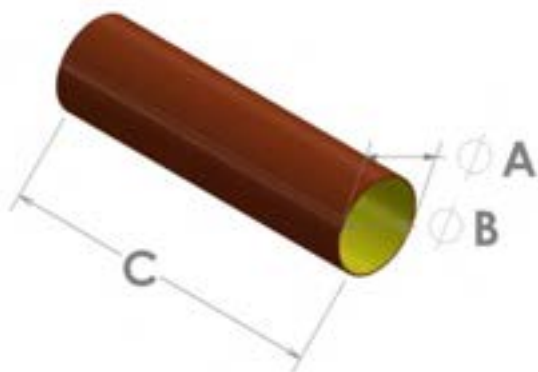

Product Code	Nominal Dia	A Max (OD)	B Min (ID)	Length C	Now Wt (kg)
HS2001	50	60	47.5	3000	13
HS3001	70	80	68.25	3000	17.7
HS4001	100	112	97.5	3000	25.2
HS6001	150	162	146.25	3000	42.2
HS8001	200	212.5	195	3000	69.3
HS10001	250	276.5	243.75	3000	99.8
HS12001	300	328.5	292.5	3000	129.7

Ductile Iron Coupling



Product Code	Nominal Dia	A	B	C	Max Torque	Now Wt (kg)
HS2012	50	117	79	69	15	0.7
HS3012	70	137	100	73	15	0.8
HS4012	100	172	132	73	15	1
HS6012	150	223	180	95	15	1.9
HS8012	200	283	240	95	15	3.4
HS10012	250	360	300	94.5	15	4.8
HS12012	300	410	350	94.5	15	5.9

Rapid Connect Couplings



Product Code	Nominal Dia	D	W	H	Now Wt (kg)
HS2002	50	70	40	80	0.1
HS3002	70	90	40	100	0.1
HS4002	100	125	46	135	0.11
HS6002	150	172	55	187	0.3
HS8002	200	227	70	244	0.6

Push Fit Couplings

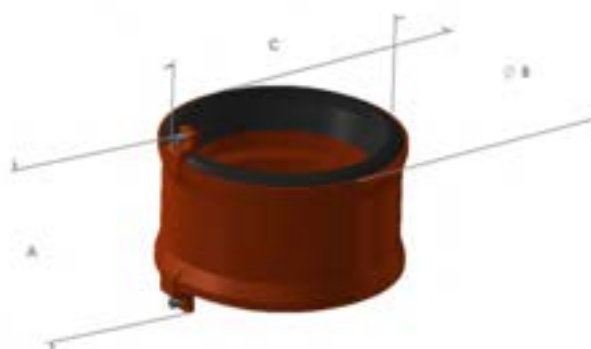

Product Code	Nominal Dia	A	B	C	Now Wt (kg)
HS4095	100	111.5	142	144.5	1.4
HS6095	150	111.5	192	194.5	2.1

• High Performance Couplings Also Available (Page 45)

88deg Short Radius Bend

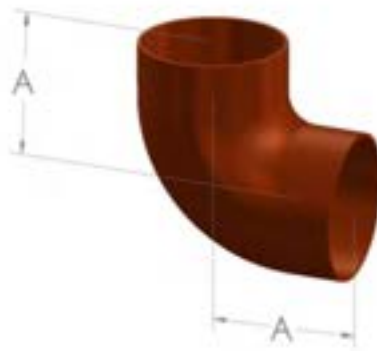

69deg Short Radius Bend

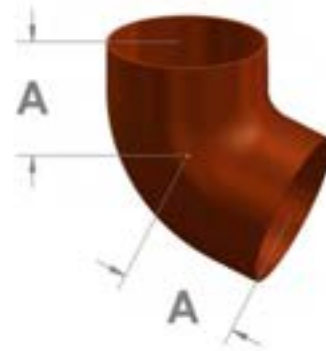

Product Code	Nominal Dia	A	Nom Wt (kg)
HS2003	50	75	0.6
HS3003	70	90	1.1
HS4003	100	110	2.1
HS6003	150	145	4.9
HS8003	200	180	9.2
HS10003	250	220	17.9
HS12003	300	260	25

Product Code	Nominal Dia	A	Nom Wt (kg)
HS2004	50	65	0.6
HS3004	70	75	0.9
HS4004	100	90	1.7
HS6004	150	120	4.6

45deg Short Radius Bend

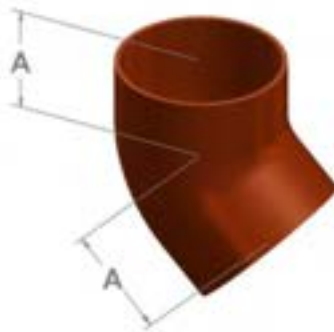

30deg Short Radius Bend

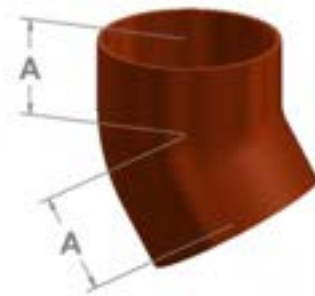

Product Code	Nominal Dia	A	Nom Wt (kg)
HS2005	50	50	0.5
HS3005	70	60	0.9
HS4005	100	70	1.6
HS6005	150	90	3.5
HS8005	200	110	6.2
HS10005	250	130	10.3
HS12005	300	155	17

Product Code	Nominal Dia	A	Nom Wt (kg)
HS2006	50	45	0.4
HS3006	70	50	0.8
HS4006	100	60	1.2
HS6006	150	80	3



15deg Short Radius Bend

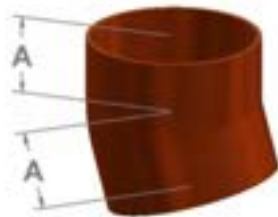

Product Code	Nominal Dia	A	Nom Wt (kg)
HS2007	50	40	0.4
HS3007	70	45	0.7
HS4007	100	50	1
HS6007	150	65	2.5

88deg Long Radius Bend



Product Code	Nominal Dia	A	B	Nom Wt (kg)
HS4008	100	269	180	5.4
HS6008	150	274	150	9.8

22deg Long Radius Bend

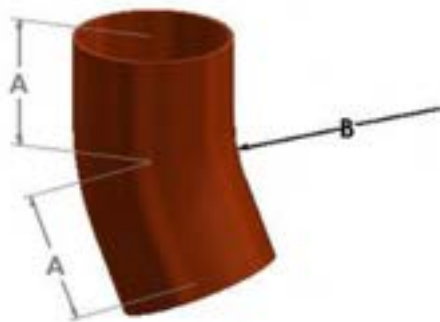

Product Code	Nominal Dia	A	B	Nom Wt (kg)
HS4009	100	90	180	1.8

30deg Short Radius Bend

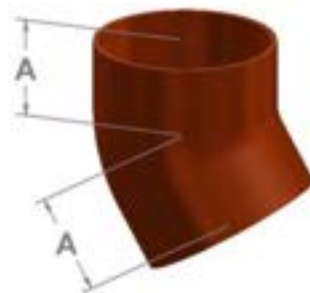

Product Code	Nominal Dia	A	Nom Wt (kg)
HS2006	50	45	0.4
HS3006	70	50	0.8
HS4006	100	60	1.2
HS6006	150	80	3

88deg Short Radius Bend - Door Back

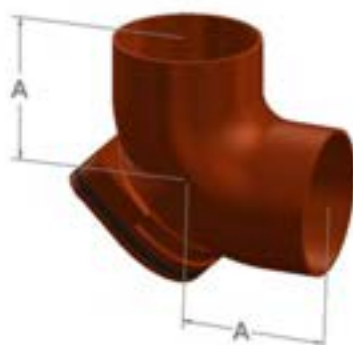

Product Code	Nominal Dia	A	Nom Wt (kg)
HS3010	70	90	1.7
HS4010	100	110	3.6

88deg Long Radius Bend - Door Back



Product Code	Nominal Dia	A	B	Nom Wt (kg)
HS4011	100	269	180	6.4
HS6011	150	274	150	10.6

88deg Bend - Long Tail



Product Code	Nominal Dia	A	B	Nom Wt (kg)
HS4013	100	110	250	4

88deg Bend - Longer Tail

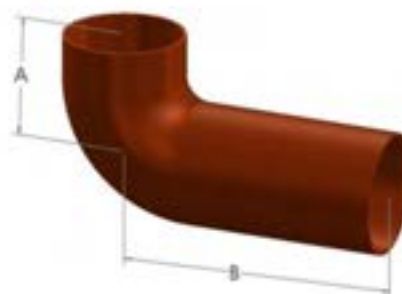

Product Code	Nominal Dia	A	B	Nom Wt (kg)
HS2013L	50	75	600	3.15
HS4013L	100	110	600	6.2



88deg Single Equal & Unequal Branch



69deg Single Equal & Unequal Branch

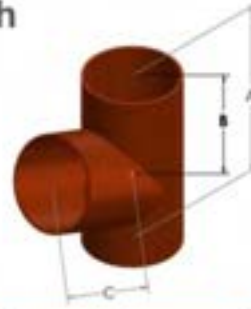

Product Code	Nominal Dia	A	B	C	Nom Wt (kg)
HS2020	50X50	145	66	80	0.9
HS3020	70X50	155	72	90	1.4
HS3021	70X70	180	83	95	1.7
HS4020	100X50	170	76	105	2.1
HS4021	100X70	190	88	110	2.4
HS4022	100X100	220	105	115	2.9
HS6020	150X100	245	115	145	5.5
HS6021	150X150	300	142	155	7.4
HS8020	200X200	380	180	200	13.2
HS10020	250X250	500	250	250	22.9
HS12020	300X300	575	275	275	29.5

Product Code	Nominal Dia	A	B	C	Nom Wt (kg)
HS2023	50X50	135	80	80	0.9
HS3023	70X50	145	90	90	1.1
HS3024	70X70	170	100	100	1.4
HS4023	100X50	155	100	110	1.7
HS4024	100X70	180	100	120	2.2
HS4025	100X100	215	130	130	2.8
HS6023	150X100	235	150	155	4.4

45deg Single Equal & Unequal Branch

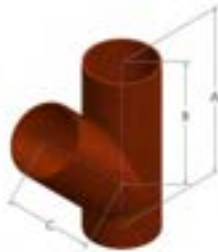

88deg Single Branch - Radius Curve



Product Code	Nominal Dia	A	B	C	Nom Wt (kg)
HS2026	50X50	187	135	134	1.3
HS3026	70X50	170	130	130	1.8
HS3027	70X70	200	145	150	2
HS4026	100X50	203	150	150	2.6
HS4027	100X70	215	170	170	2.8
HS4028	100X100	275	206	210	4.2
HS6026	150X100	294	231	231	6.4
HS6027	150X150	355	265	265	9
HS6028	150X70	235	205	205	4.9
HS8026	200X100	300	260	260	9.1
HS8027	200X150	375	300	300	13.2
HS8028	200X200	455	340	340	16.8
HS10028	250X250	560	430	430	31.5
HS12028	300X300	660	505	505	50.1

Product Code	Nominal Dia	A	B	C	Nom Wt (kg)
HS4030	100X100	260	102	150	3.5
HS6030	150X100	375	157	230	8
HS6031	150X150	400	140	260	10

88deg Single Branch - Radius with Access



88deg Double Branch

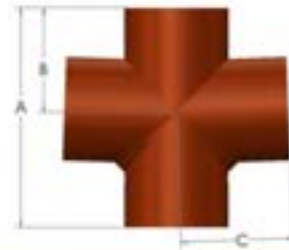

Product Code	Nominal Dia	A	B	C	Nom Wt (kg)
HS4032	100X100	270	102	150	5.2
HS6032	150X100	300	117	202	8.4
HS6033	150X150	400	140	260	11.4

Product Code	Nominal Dia	A	B	C	Nom Wt (kg)
HS4034	100X100	233	111	119	3.2

69deg Double Branch



45deg Double Branch



Product Code	Nominal Dia	A	B	C	Nom Wt (kg)
HS4035	100X100	215	130	130	3.6

Product Code	Nominal Dia	A	B	C	Nom Wt (kg)
HS4036	100X100	260	190	190	5.3
HS6036	150X100	280	225	225	7.2
HS6037	150X150	355	265	265	12.5
HS8036	200X200	455	340	340	22.3



88deg Double Branch - Radius

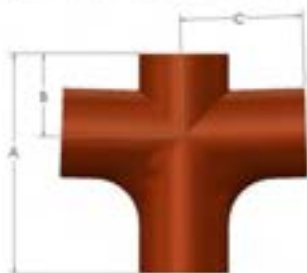

Product Code	Nominal Dia	A	B	C	Nom Wt (kg)
HS4038	100X100	270	102	150	4.8
HS6038	150X100	300	115	200	6.8

88deg Long Tail Branch



Product Code	Nominal Dia	A	B	C	Nom Wt (kg)
HS4040	100X100	430	105	115	4.8

88deg Long Tail 4 Boss Branch

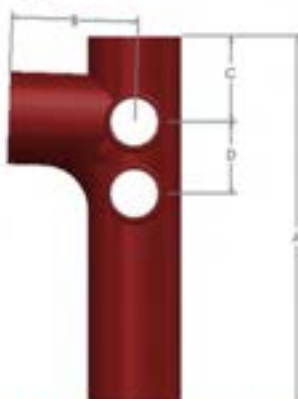

Product Code	Nominal Dia	A	B	C	D	Nom Wt (kg)
HS4059	100X100	500	150	102	85	6.2

88deg Long Tail Corner Branch



Product Code	Nominal Dia	A	B	C	Nom Wt (kg)
HS4041	100X100	430	105	115	6.3

88deg Short Tail Corner Branch

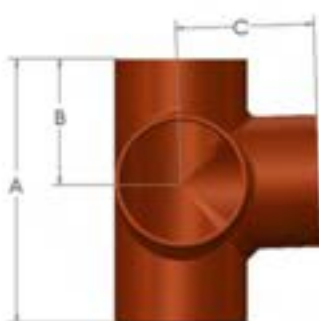

Product Code	Nominal Dia	A	B	C	Nom Wt (kg)
HS4042	100x100	220	105	115	4

HALIFAX SOIL



KM 684754

BS EN 877



Hargreaves Foundry Drainage

A1

Access Pipe - Round Door

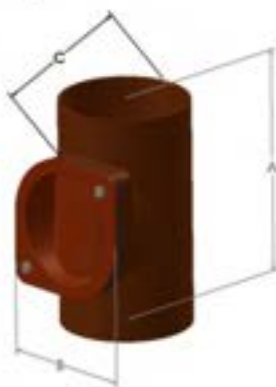

Product Code	Nominal Dia	A	B	C	Nom Wt (kg)
HS2043	50	170	80	76	2
HS3043	70	205	98	92	2.4
HS4043	100	250	118	130	4
HS6043	150	280	172	180	7.5

Access Pipe - Rect Door

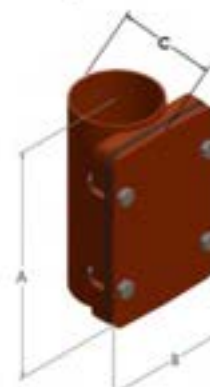

Product Code	Nominal Dia	A	B	C	Nom Wt (kg)
HS4049	100	320	160	130	7.8
HS6049	150	395	215	185	16
HS8049	200	465	260	233	23.2
HS10049	250	570	335	325	37.9
HS12049	300	635	385	370	47.1

P Traps with Bottom Access



Product Code	Nominal Dia	A	B	Nom Wt (kg)
HS2050	50	160	115	2.1
HS3050	70	200	140	4
HS4050	100	255	175	5.8
HS6050	150	350	245	11.8

Plain P Traps

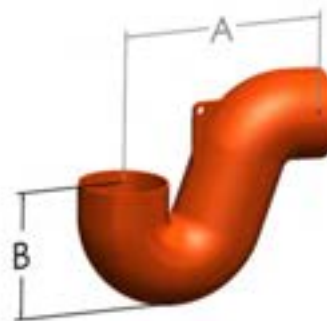

Product Code	Nominal Dia	A	B	Nom Wt (kg)
HS4080	100	255	158	4.6



Offsets



Product Code	Nominal Dia	A	B	Nom Wt (kg)
HS4044	100	75	215	2.5
HS2045	50	130	230	1.4
HS3045	70	130	250	2.1
HS4045	100	130	270	3.2

Pipe Tapers



Product Code	Nominal Dia	A	Nom Wt (kg)
HS3046	70X50	78	0.6
HS4046	100X50	80	0.9
HS4047	100X70	88	0.9
HS6046	150X50	102	2
HS6047	150X70	100	2.2
HS6048	150X100	102	2.2
HS8046	200X100	115	4.5
HS8047	200X150	125	4.5
HS10046	250X100	115	5
HS10047	250X150	140	6
HS10048	250X200	145	6.2
HS12046	300X150	150	9.4
HS12047	300X200	160	9.8
HS12048	300X250	170	10.2

Blank Ends



Product Code	Nominal Dia	A	Nom Wt (kg)
HS2051	50	30	0.3
HS3051	70	35	0.6
HS4051	100	40	1.2
HS6051	150	50	2.5
HS8051	200	60	4.3
HS10051	250	70	7.2
HS12051	300	80	10.9

Drilled & Tapped Blank Ends



Product Code	Nominal Dia	A	Nom Wt (kg)
HS4052	100	40	0.8
HS6052	150	50	1.7

Single Boss Pipe 2" BSPT

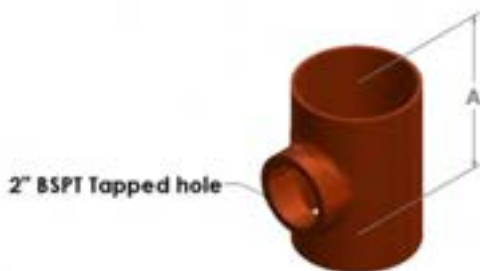

Product Code	Nominal Dia	A	Nom Wt (kg)
HS3053	70	148	1.4
HS4053	100	155	2.1
HS6053	150	175	3.6

Double Boss Pipe 2 x 2" BSPT

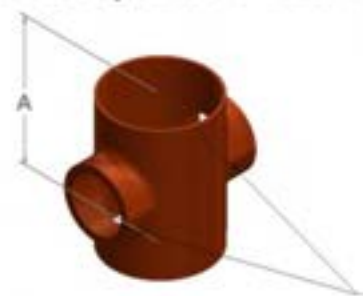

Product Code	Nominal Dia	A	Nom Wt (kg)
HS4054	100	155	1.9

Double Boss Pipe 2 x 2" BSPT at 90deg

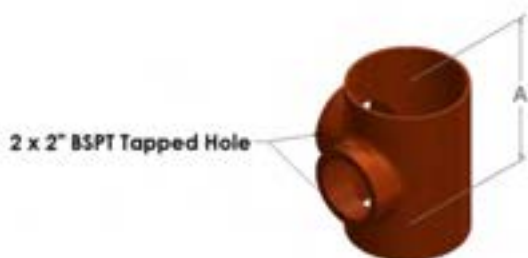

Product Code	Nominal Dia	A	Nom Wt (kg)
HS4055	100	155	2

Compression Fit Boss Pipe



Product Code	Nominal Dia	A	Nom Wt (kg)
HS3090	70	148	1.7
HS4090	100	155	2.2
HS6090	150	175	4.3

Double Compression Fit Boss Pipe

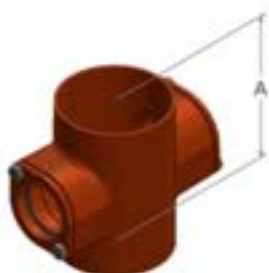

Product Code	Nominal Dia	A	Nom Wt (kg)
HS4092	100	155	3.3

Double Compression Fit Boss Pipe at 90deg



Product Code	Nominal Dia	A	Nom Wt (kg)
HS4091	100	155	3.3



Manifold Connector

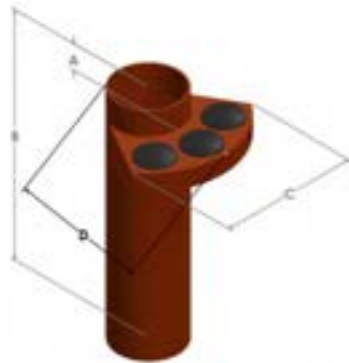

Product Code	Nominal Dia	A	B	C	D	Nom Wt (kg)
HS4058	100	42	396	218	190	5.1

Stack Support Pipe

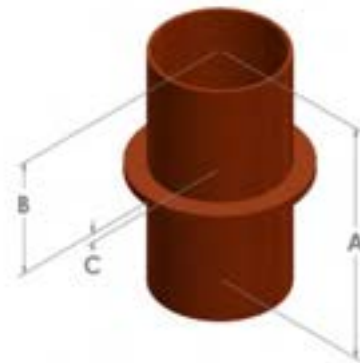

Product Code	Nominal Dia	A	B	C	Nom Wt (kg)
HS3056	70	202	102	8	1.7
HS4056	100	202	102	8	2.6
HS6056	150	202	102	8	4.1
HS8056	200	210	102	8	6.5

Stack Support Pipe Bracket

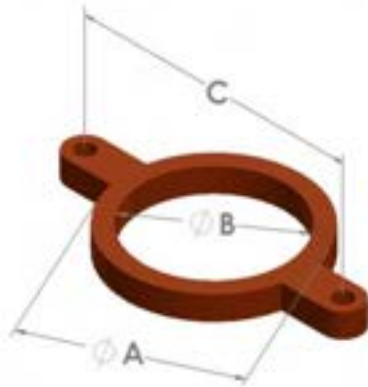

Product Code	Nominal Dia	A	B	C	Nom Wt (kg)
HS3057	70	106	85	170	0.9
HS4057	100	145	117	214	1.4
HS6057	150	195	167	255	1.8
HS8057	200	245	218	310	2.2

Stack Support Console



Product Code	Nominal Dia	Nom Wt (kg)
HS4070	100	2.1

Coated Adjustable Bracket

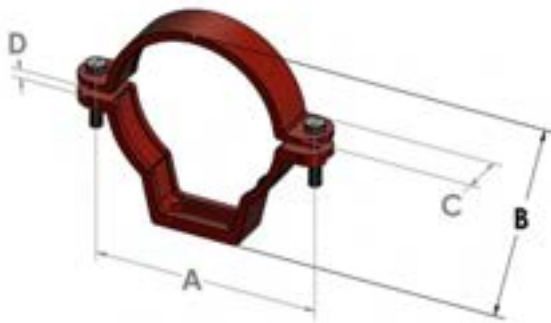

Product Code	Nominal Dia	A	B	C	D	Slot	Nom Wt (kg)
HS2067	50	86	98	28	6	22X11	0.34
HS3067	70	110	118	28	6	30X11	0.48
HS4067	100	152	146	30	8	50X13.5	0.58
HS6067	150	198	198	30	8	50X13.5	0.74
HS8067	200	240	260	36	8	66X12.5	1.6

\*Not covered by EN877 standard or Kitemark

Halifax Grip



Product Code	Nominal Dia	Nom Wt (kg)
HS2060	50	0.38
HS3060	70	0.52
HS4060	100	0.7
HS6060	150	0.9
HS8060	200	2.5

\*Not covered by EN877 standard or Kitemark

Bismat Bracket

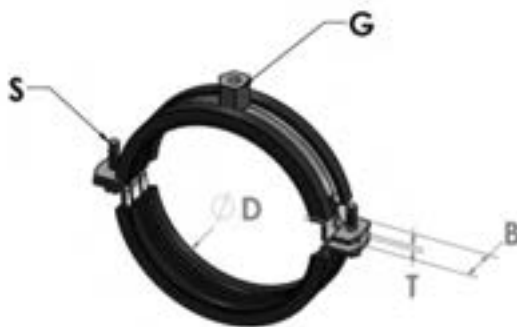

Product Code	Nom Dia	D	G (dia)	S (dia)	BxT	Load Fa,z (N)	Nom Wt (kg)
HS2061	50	58-63	M8/M10	M6	20X1.25	800	0.09
HS3061	70	73-80	M8/M10	M6	23X2.0	520	0.12
HS4061	100	108-114	M8/M10	M6	25X2.5	935	0.18
HS6061	150	159-168	M10	M8	25X3.0	1220	0.45
HS8081	200	210-219	M10	M8	25X3.0	1220	0.68

\*Not covered by EN877 standard or Kitemark

Halifax Heavy Duty Bossed Bracket

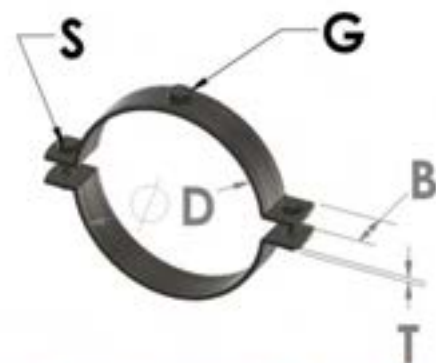

Product Code	Nom Dia	D	G (dia)	S (dia)	BxT	Load Fa,z (N)	Nom Wt (kg)
HS2063	50	59-65	M8/M10	M6	20X1.25	950	0.06
HS3063	70	79-85	M10/M12	M8	30X3.0	1400	0.19
HS4063	100	108-116	M10/M12	M8	30X3.0	4000	0.25
HS6063	150	159-169	M10/M12	M10	38X4.0	8200	0.78
HS8063	200	203-213	M10/M12	M10	38X4.0	8200	1.05

\*Not covered by EN877 standard or Kitemark



Heavy Duty Bossed Bracket Lined

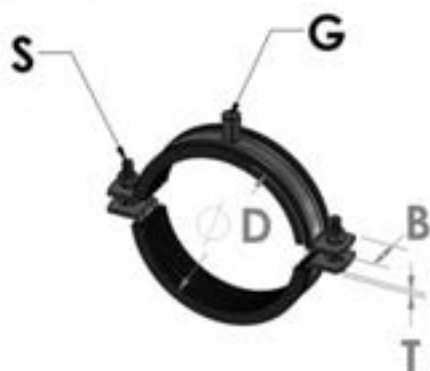

Product Code	Nom Dia	D	G (dia)	S (dia)	BxT	Load Fa,z (N)	Nom Wt (kg)
HS2064	50	59-64	M8/M10	M8	30X2.5	1500	0.28
HS3064	70	79-85	M10/M12	M8	30X3.0	2300	0.38
HS4064	100	108-116	M10/M12	M8	30X3.0	2300	0.45
HS6064	150	159-169	M10/M12	M10	38X4.0	3800	0.84
HS8064	200	203-213	M12	M10	38X4.0	3800	1.15

\*Not covered by EN877 standard or Kitemark

Split Band Clip



Product Code	Nom Dia	A	WxT	D(mm)	Bolt F	Nom Wt (kg)
HS2065	50	110	30X3	56	M10X30	0.24
HS3065	70	129	30X3	77	M10X30	0.29
HS4065	100	168	40X3	109	M10X30	0.33
HS6065	150	225	40X3	159	M12X40	0.61
HS8065	200	282	40X5	212	M12X40	1.15

\*Not covered by EN877 standard or Kitemark

\*High Performance Coupling



Product Code	Dia	Bolt Size	Width (mm)	Nom Wt (kg)
HS2069	50	M8	88	0.85
HS3069	70	M10	88	0.95
HS4069	100	M10	88	1.41
HS6069	150	M12	115	3.15
HS8069	200	M16	120	6.9

\*Not covered by EN877 standard or Kitemark

Wall Plate Type 670

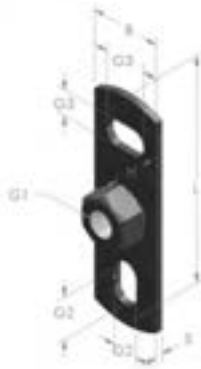

Product Code	G1	H (mm)	A (mm)	B x S (mm)	L (mm)	G2 (mm)	G3 (mm)	Safe Load (n)	Wt (kg)
HSD6702	M10	10	50	25X3.0	80	15X8.5	15X8.5	2500	0.05
HSD6711	M10	10	100	38X4.0	145	30X11	25X11	3500	0.15

\*Not covered by EN877 standard or Kitemark

Thread Adaptor



Product Code	G1 (male)	G2 (female)	Wt (kg)
HSD10/12*	M10	M12	0.03

\*Not covered by EN877 standard or Kitemark

Galv. Cantilever Arms



Product Code	Length (mm)	Strut (mm)	Max Load (n)	Wt (kg)
HSD1830	300	41x41	150	0.93
HSD1845	450	41x41	75	1.22

\*Not covered by EN877 standard or Kitemark

Rapid Strut Cantilever Arm



Product Code	Length (mm)	Strut (mm)	Max Load (n)	Wt (kg)
HSD1846	450	41x41x2.5	881	1.25

\*Not covered by EN877 standard or Kitemark

Acoustic Dampener



Product Code	Size	Nom Wt (kg)
HSD6703	M10	0.2

\*Not covered by EN877 standard or Kitemark





# HALIFAX DRAIN



*Mechanically Jointed Cast Iron Systems*

## PRODUCT TABLES

*Fully Compliant with*

**BS EN 877:1999 + A1:2006**

**BS EN 877:2021**



**KM 684754**

**BS EN 877**

**Double Spigot Pipes**

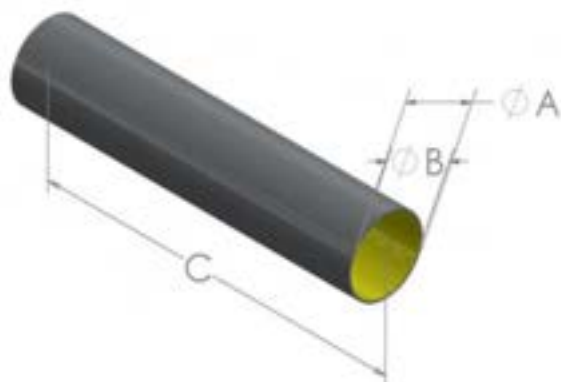

Product Code	Nominal Dia	A Max (OD)	B Min (ID)	Length C	Now Wt (kg)
HD4001	100	112	97.5	3000	25.6
HD6001	150	162	146.25	3000	41
HD8001	200	212.5	195	3000	68
HD10001	250	276.5	243.75	3000	99.8
HD12001	300	328.5	292.5	3000	129.7

**Ductile Iron Coupling**



Product Code	Nominal Dia	A	B	C	Max Torque	Now Wt (kg)
HD4012	100	172	132	73	15	1.2
HD6012	150	223	180	95	15	2.1
HD8012	200	283	240	95	15	3.3
HD10012	250	360	300	94.5	15	4.8
HD12012	300	410	350	94.5	15	5.9

**Push Fit Couplings**



Product Code	Nominal Dia	A	B	C	Now Wt (kg)
HD4095	100	111.5	142	144.5	1.4
HD6095	150	111.5	192	194.5	2.0

**Ductile Iron Coupling With Continuity**



Product Code	Nominal Dia	A	B	C	Max Torque	Now Wt (kg)
HD4012C	100	172	132	73	15	1.2
HD6012C	150	223	180	95	15	2.1
HD8012C	200	283	240	95	15	3.3
HD10012C	250	360	300	94.5	15	4.8
HD12012C	300	410	350	94.5	15	5.9

• High Performance Couplings Also Available (Page 45)



45deg Short Radius Bend

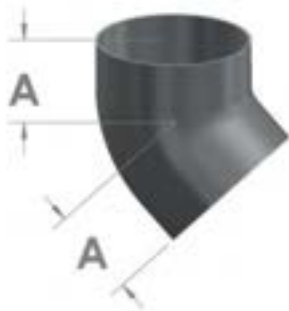

30deg Short Radius Bend

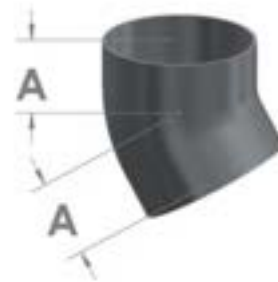

Product Code	Nominal Dia	A	Nom Wt (kg)
HD4005	100	70	1.5
HD6005	150	90	3.3
HD8005	200	110	5.8
HD10005	250	130	10.3
HD12005	300	155	17.3

Product Code	Nominal Dia	A	Nom Wt (kg)
HD4006	100	60	1.5
HD6006	150	80	3.2

15deg Short Radius Bend

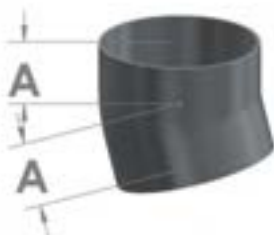

88deg Long Radius Bend

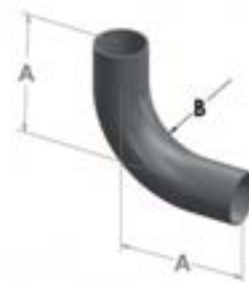

Product Code	Nominal Dia	A	Nom Wt (kg)
HD4007	100	50	1
HD6007	150	65	2.5

Product Code	Nominal Dia	A	B	Nom Wt (kg)
HD4008	100	269	180	4.8
HD6008	150	274	150	8.2

22deg Long Radius Bend

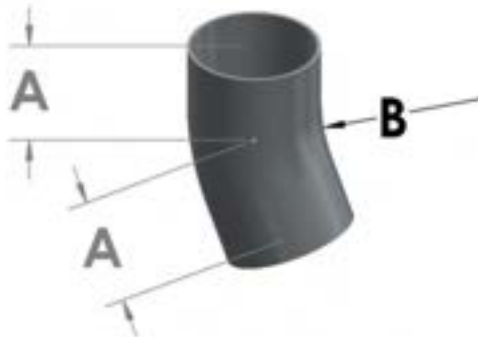

Product Code	Nominal Dia	A	B	Nom Wt (kg)
HD4009	100	90	180	1.8

88deg Long Radius Bend - Door Back

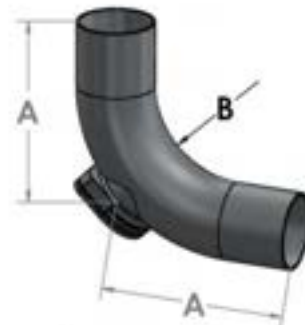

Product Code	Nominal Dia	A	B	Nom Wt (kg)
HD4011	100	269	180	6.4
HD6011	150	274	150	10.7

88deg Long Radius Bend - Heel Rest

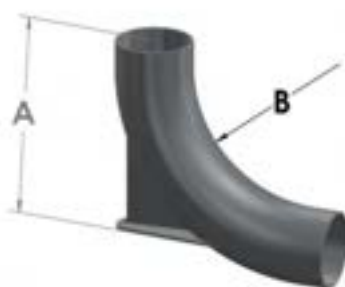

Product Code	Nominal Dia	A	B	Nom Wt (kg)
HD4014	100	269	180	5.6
HD6014	150	274	150	9.1

45deg Medium Radius Bend



Product Code	Nominal Dia	A	B	Nom Wt (kg)
HD4015	100	135	150	2.8
HD6015	150	145	150	4.3



**69deg Single Equal & Unequal Branch**

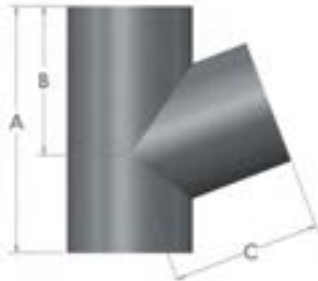

**45deg Single Equal & Unequal Branch**

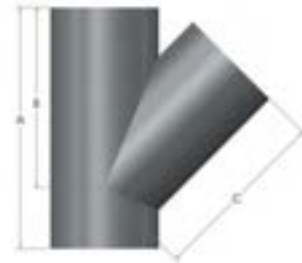

Product Code	Nominal Dia	A	B	C	Nom Wt (kg)
HD4025	100X100	215	130	130	3
HD6023	150X100	235	150	155	4.4

Product Code	Nominal Dia	A	B	C	Nom Wt (kg)
HD4028	100X100	275	206	210	4.3
HD6026	150X100	294	231	231	6.4
HD6027	150X150	355	265	265	9
HD6028	150X70	235	205	205	4.9
H58026	200X100	300	260	260	9.1
HD8027	200X150	375	300	300	13.2
HD8028	200X200	455	340	340	16.8
HD10028	250X250	560	430	430	31.5
HD12028	300X300	660	505	505	50.1

**88deg Single Branch - Radius Curve**



**88deg Single Branch - Radius Curve with Access**



Product Code	Nominal Dia	A	B	C	Nom Wt (kg)
HD4030	100X100	260	102	150	3.5
HD6030	150X100	375	157	230	8
HD6031	150X150	400	140	260	12

Product Code	Nominal Dia	A	B	C	Nom Wt (kg)
HD4032	100X100	270	102	150	5.4
HD6032	150X100	300	117	202	9.5
HD6033	150X150	400	140	260	14.2

69deg Double Branch

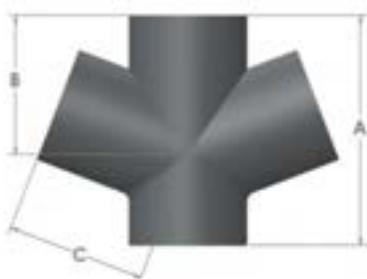

45deg Double Branch

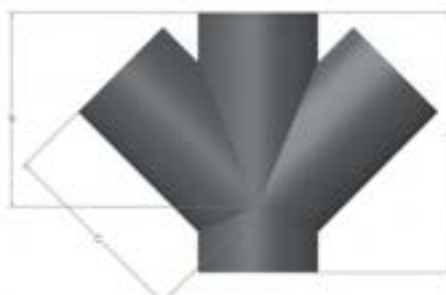

Product Code	Nominal Dia	A	B	C	Nom Wt (kg)
HD4035	100X100	215	130	130	4.1

Product Code	Nominal Dia	A	B	C	Nom Wt (kg)
HD4036	100X100	260	190	190	5.5
HD6036	150x100	280	225	225	6.5
HD6037	150X150	355	265	265	12.5
HD8036	200X200	455	340	340	23.7

88deg Double Branch - Radius Curve



Product Code	Nominal Dia	A	B	C	Nom Wt (kg)
HD4038	100X100	270	102	150	5
HD6038	150X100	300	115	200	9.3

**HALIFAX DRAIN**



BS EN 877



KM 684754

Hargreaves Foundry Drainage  
A2-S1, d0



Access Pipes - Round Door



Product Code	Nominal Dia	A	B	C	Nom Wt (kg)
HD4043	100	250	118	130	4
HD6043	150	280	172	180	7.3

Access Pipes - Rect Door



Product Code	Nominal Dia	A	B	C	Nom Wt (kg)
HD4049	100	320	160	130	7.9
HD6049	150	395	215	185	13.1
HD8049	200	465	260	233	23.8
HD10049	250	570	335	325	39.6
HD12049	300	635	385	370	50.2

Pipe Tapers



Product Code	Nominal Dia	A	Nom Wt (kg)
HD6048	150X100	102	1.9
HD8046	200X100	115	4
HD8047	200X150	125	3.4
HD10046	250X100	115	5.3
HD10047	250X150	140	6.3
HD10048	250X200	145	6.4
HD12046	300X150	150	9.4
HD12047	300X200	160	9.8
HD12048	300X250	170	10.2

Coated Adjustable Bracket



Product Code	Nominal Dia	A	B	C	D	Slot	Nom Wt (kg)
HD4067	100	152	146	30	8	50X13.5	0.58
HD6067	150	198	198	30	8	50X13.5	0.74
HD8067	200	240	260	36	8	66X12.5	1.6

\*Not covered by EN877 standard, Kitemark or Agrément certificate

P Trap with Bottom Access



Product Code	Nominal Dia	A	B	Nom Wt (kg)
HD4050	100	255	175	4
HD6050	150	350	245	9.9

Plain P Traps

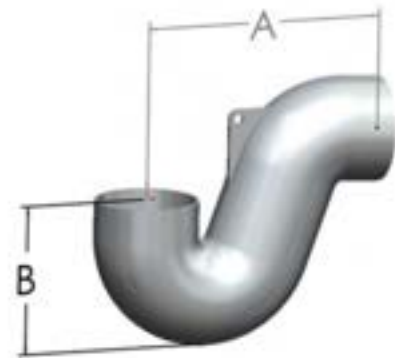

Product Code	Nominal Dia	A	B	Nom Wt (kg)
HD4080	100	255	158	4.6

Blank Ends



Product Code	Nominal Dia	A	Nom Wt (kg)
HD4051	100	40	0.9
HD6051	150	50	1.6
HD8051	200	60	3
HD10051	250	70	7.2
HD12051	300	80	10.9

Blank Ends - Drilled & Tapped



Product Code	Nominal Dia	A	Nom Wt (kg)
HD4052	100	40	0.7
HD6052	150	50	1.7



**Bellmouth Gully Inlet**



Product Code	Spigot Dia	A	B	C	Nom Wt (kg)
HD4070	100	215	25	85	2.4

**Bellmouth Gully with Secured Grating**



Product Code	Nominal Dia	Nom Wt (kg)
HD4071	100	4.5

**Gully Inlet**



Product Code	Spigot Dia	A	B	C	Nom Wt (kg)
HD6071	150	215	22	95	3.4

**Solid Cover**



Product Code	Nominal Dia	Nom Wt (kg)
HD8076	200	2

Supplied with Rubber Seal + Screws.  
\* Not Covered by Kitemark

**Plain Grating**



Product Code	Nominal Dia	Nom Wt (kg)
HD8077	197	1.8

\* Not Covered by Kitemark

**Puddle Flanges**



Product Code	Nominal Dia	A	B	C	Nom Wt (kg)
HD4078	100	220	12	50	4
HD6078	150	275	12	65	6
HD8078	200	315	12	70	7
HD10078	250	390	12	75	10.4
HD12078	300	450	12	80	12.6

Bolt on flange is supplied in two halves with stainless steel nuts & bolts.

*Solid Cover & Plain Grating are suitable for use with Standard & Bellmouth Gully Inlets*

Inspection Chamber - 2 Branch - Round Door

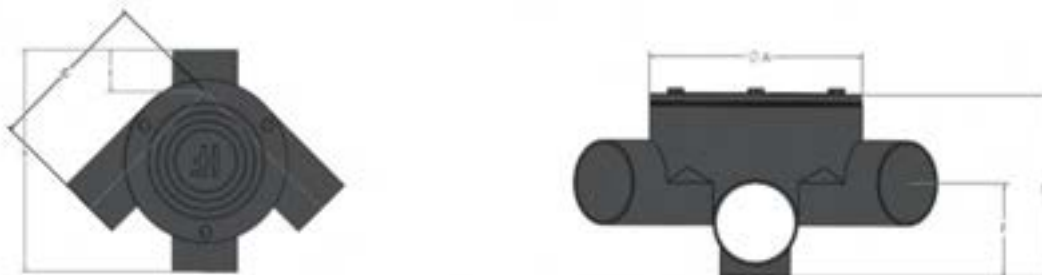

Product Code	Nominal Dia	A	B	C	D	E	F	Nom Wt (kg)
HD4480	100X100	275	375	290	235	72	66	12
HD6480	150X100	275	415	334	259	100	93	15
HD6680	150X150	375	415	317	310	126	92	16.6

Inspection Chamber - 2 Branch - Rect Door

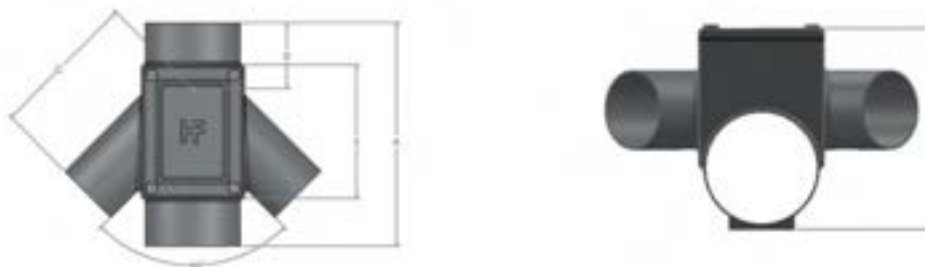

Product Code	Nominal Dia	A	B	C	D	E	Nom Wt (kg)
HD4481	100X100	350	200	250	111	200	11.7
HD6481	150X100	375	275	250	111	225	20.5
HD6681	150X150	435	275	300	136	295	20.7

Inspection Chamber - 4 Branch - Rect Door

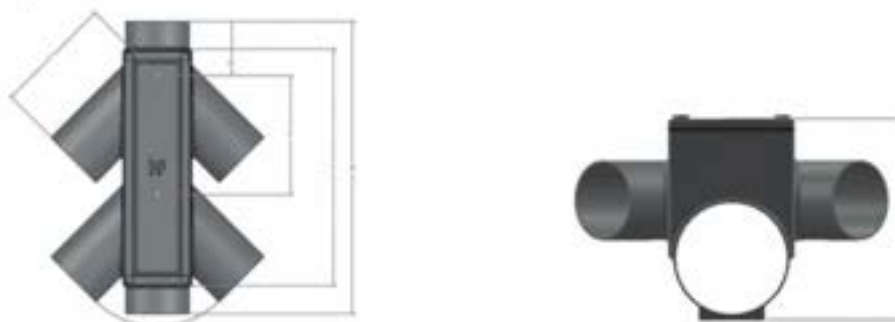

Product Code	Nominal Dia	A	B	C	D	E	F	Nom Wt (kg)
HD4482	100X100	590	200	250	111	450	250	21.5
HD6482	150X100	625	275	250	111	475	250	29
HD6682	150X150	735	275	300	136	595	300	45.5



# HALIFAX SOIL & DRAIN



*Mechanically Jointed Cast Iron Systems*

## INSTALLATION

*Fully Compliant with*

**BS EN 877:1999 + A1:2006**

**BS EN 877:2021**



**KM 684754**

**BS EN 877**

## Safe Practice

The first consideration for any on site installation work should be safety. Information relating to managing health and safety in construction can be found in Guidance on the Construction (Design and Management) Regulations 2015.

### L153

#### Key Elements to Securing Construction Health & Safety

The key elements include:

- a) Managing the risks by applying the general principles of prevention
- b) Appointing the right people and organisations at the right time
- c) Making sure everyone has the information, instruction, training and supervision they need to carry out their jobs in a way that secures health and safety
- d) Duty holders cooperating and communicating with each other and coordinating their work; and
- e) Consulting workers and engaging with them to promote and develop effective measures to secure health, safety and welfare





## Jointing Method for Couplings

### Ductile Iron Couplings -

#### Step 1

Check the components – two-part coupling and EPDM gasket, 2 x M8 bolts and nuts (up to 100 mm diameter pipes, 4 x M8 nuts and bolts for 150mm diameter and above). Ensure the 2 grub screws for electrical continuity are present (shown below inserted into casting).



#### Step 2

Fit the gasket to the lower pipe/fitting first, line up the upper component and fit carefully into place. Make sure the two components are square and parallel and line up correctly with the gasket.

#### Step 3

Line up the two parts of the coupling ensuring they fit correctly over the gasket. At this point check that the two grub screws for electrical continuity do not protrude on the inside of the coupling.



#### Step 4

Bolt the two parts of the coupling together and gradually tighten, ensuring an equal distance is maintained during assembly. Do not over tighten or tighten only one side at a time. We recommend the use of a torque wrench at 15Nm.

#### Step 5

Adjust the grub screws until each is lightly touching the pipe then give them a final half turn. This normally will be adequate to allow metal to metal contact and provide electrical continuity – do not over tighten.



Rapid Connect Couplings -

**Step 1**

Rapid connect pipe coupling supplied complete with EPDM gasket and electrical continuity provision



**Step 2**

Push the coupling onto the end of the pipe or fitting up to the gasket's central register.

**Step 3**

Push the next pipe or fitting into the coupling making sure that the cut pipes are square.



**Step 4**

Tighten the set screw using;

- 6mm allen key /socket adaptor (50 – 150mm)
- 8mm allen key/socket adaptor (200mm)

Note: due to the block tightening feature the joint cannot be overtightened and this also ensures the sharp edges of coupling cut through the painted finish to provide electrical continuity

**Tools for Coupling Assembly**

Rapid connect pipe coupling supplied complete with EPDM gasket and electrical continuity provision

Description	Code
1/2 Inch Drive Ratchet Spanner	HSD001
6mm Allen Socket Adaptor	HSD003
8mm Allen Socket Adaptor	HSD004
14mm Socket - for Access Door Bolts	HSD002



## Push Fit Couplings -

### Step 1

Apply a small amount of lubricant [*HS0001 / HD0001*] to the rubber gasket and to the spigot of the pipe/fitting to be inserted.



### Step 2

Push the socket onto the spigot and ensure that the spigot is fully inserted and abutting the central register. It is important to ensure that the socket and spigot are correctly aligned before beginning to ease the connection.

### Step 3

Lubricate the other gasket and spigot and push the components together to form a joint as above.



### Step 4 - ( Halifax Soil Push fit Coupling Only )

Adjust the grub screws until each is lightly touching the pipe then give them a final half turn. This normally will be adequate to allow metal to metal contact and provide electrical continuity – do not over tighten.

## Installation Above Ground

### Securing Brackets to Walls

Securing bracketry to supporting structures is primarily dependent upon the condition of the proposed structure. To this end, the methods employed for securing the bracketry should be decided upon by the designers and installers for each project on an individual basis dependent upon the design and condition of the structure in the desired location.

It would be advisable to check the fixing requirements for each bracket (See HFDS 107 – Product Tables) prior to placement of order to ensure suitability for the application and availability of the required fixings.

### Vertical Pipework Support

For vertical soil and rainwater stacks load bearing brackets should be provided every 3m maximum at each floor level. These brackets should be securely fixed and tightened as the installation proceeds so as to adequately support the pipework and its contents and prevent unnecessary load at the base of the stack. Where fittings are installed within the vertical stack it is recommended that additional brackets are provided to ensure alignment of the pipework.



### Stack Support Pipe

On multi storey buildings there may be a requirement for additional support in the form of stack support pipes, see table below. When installing stack support pipes these should be positioned at ground floor and every subsequent fifth floor where average floor to ceiling height is 2.5 metres.

We recommend either the Halifax Stack Support Console combined with a Stack Support Pipe or alternatively Cantilever Arms supporting a Stack Support Bracket and Stack Support Pipe (see illustrations for both).



## Installation Above Ground

### Low Gradient Horizontal Pipework Support

BS EN 12056-2 Code of Practice advises the distance between pipe supports should not exceed 3 metres. We would however, recommend two brackets per 3 metre pipe length, the first being positioned within 500mm of coupling joint and the next to be maximum 2m spacing. This will aid installation and provide greater rigidity.

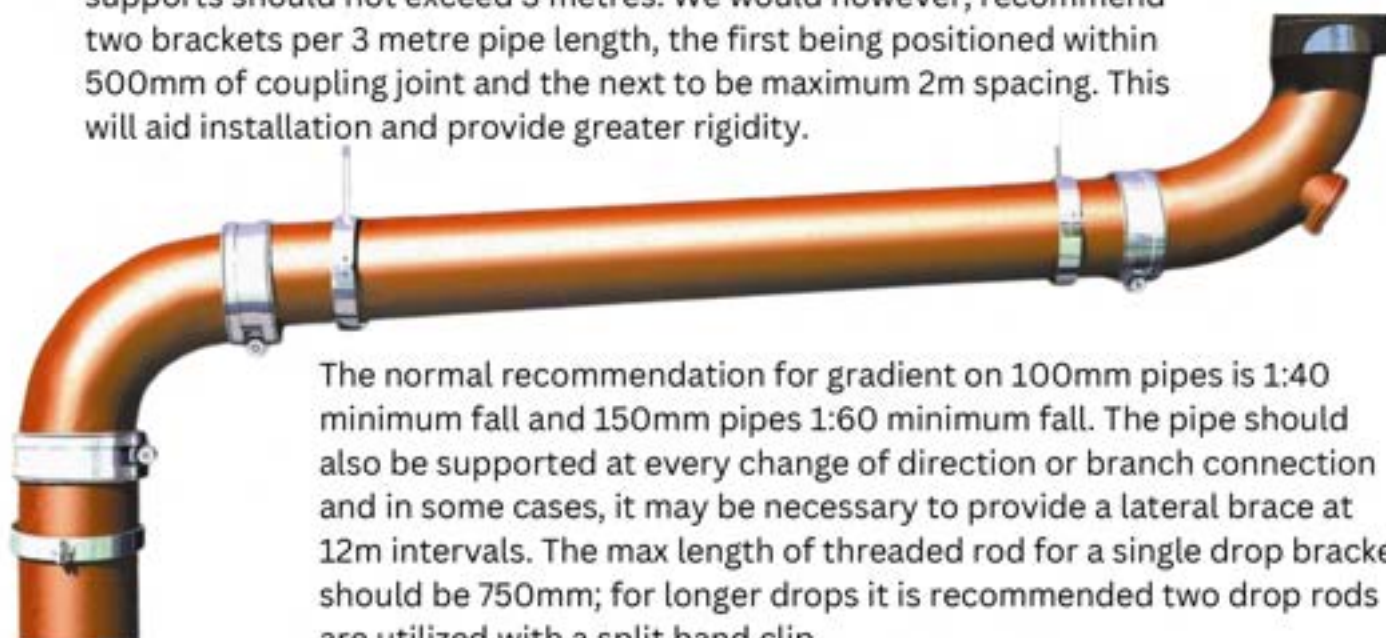

The normal recommendation for gradient on 100mm pipes is 1:40 minimum fall and 150mm pipes 1:60 minimum fall. The pipe should also be supported at every change of direction or branch connection and in some cases, it may be necessary to provide a lateral brace at 12m intervals. The max length of threaded rod for a single drop bracket should be 750mm; for longer drops it is recommended two drop rods are utilized with a split band clip.

### Acoustic Dampener

For best results the dampener bracket (HSD6703) should be used in conjunction with the Bismat bracket as indicated by the figures in the Technical Submittal Document (HFDS 075).

The dampener should be positioned with a 10mm gap between it and the supporting structure. A 16mm gap should then be left between the dampener and Bismat bracket. See image for indicative positions.



### Halifax Manifold Connection

This multi-waste connector allows up to 3 waste pipes from various appliances e.g. sinks, basins and showers to be connected at a single internal point above finished floor level. The rubber grommets in the manifold connector may be cut to accept 32 & 40mm plastic or 35 and 42mm copper. The manifold body is connected to the stack by standard ductile iron couplings (HS4012) or stainless-steel couplings (HS4002).



- 1) Remove grommets and pierce appropriate size hole to suit waste pipe. If any of the connections are not to be used save a grommet for blanking off.
- 2) Apply a small amount of silicone grease (not supplied) to the outside of grommets and re-fit into manifold. Ensure the grommet retaining groove is correctly located in the manifold casing.
- 3) Lubricate pipe ends before insertion into grommet with a rotational movement. We recommend pipe ends are chamfered to ease assembly.
- 4) Any blank grommet must be fitted as point 2 above.

### WC Connection

The Halifax system accepts Multikwik and similar push fit WC connectors

### PVC Above Ground Soil Systems

100 & 150mm Halifax to PVC use standard Ductile Iron or Stainless-Steel Couplings

### Conventional Cast Iron Soil/Drain

To connect Halifax into a conventional socket use a traditional caulked joint.

### Below Ground Clayware

Halifax can be connected to a clay or earthenware socket using a traditional cement joint. When connecting to Supersleve/Hepsleve use the appropriate adaptor coupling by Hepworth.

### Roof Outlets / Floor Drains

In most cases our standard couplings will connect directly onto the majority of products available on the market, but if in doubt, contact us to check on compatibility.



## Installation Below Ground

### Buried Pipelines

While both pipe systems use the same 2-pack Epoxy coating, the coating used on the Halifax Drain system is thicker than that used on the Halifax Soil system and as such, has a higher resistance to chemical attack. This makes the Halifax Drain system more suited to being buried in the ground. It should be noted however that where the products are to be placed in particularly aggressive soils (e.g. peat) where the PH value is less than 6, it is recommended that the pipe system be encased in polyethylene sleeves for additional protection.

### Trench Preparation

Halifax drainage may be laid directly into an accurately trimmed trench allowing 50mm clearance beneath each coupling joint. The bottom of the trench should be flat to provide continuous support. Where accurate trimming cannot be achieved due to the subsoil condition, it will be necessary to excavate an additional 100mm to allow a granular bed to be laid whilst still maintaining the 50mm clearance beneath each joint.

### Concrete Encasement

In a situation where the pipes need to be encased in concrete, provided the applied coating is dense, undamaged and free from bare patches and lack of adhesion, they will form a barrier between the cast iron and the concrete therefore making either system suitable for use. However, due to the thicker coating mentioned above, if we were to recommend a product system to be completely encased in concrete (as opposed to a short length passing through a concrete wall/foundation), the Halifax Drain system would be the most appropriate. In the event that the concrete encasement becomes damaged or is not fully coherent, the painted surface of the casting may be required to form a barrier between the otherwise exposed cast iron and any encroaching aggressive substances.

### Bedding in Concrete

When a concrete bed is required prepare the trench as above to provide 100mm of concrete under the pipe but support the pipe on a compressible material (expanded polystyrene) either side of each joint. If the pipework is being surrounded in concrete provision should be made for a flexible joint, within the concrete, at 5m intervals and placed next to a pipe joint. This should be made of suitable compressible material and cover the full cross-sectional area of the concrete. It is recommended that inspection and testing of the pipework is completed in sections prior to haunching and surround with concrete.

### Settlement

Pipework leaving buildings and manholes which may be subject to settlement should incorporate a minimum of two joints close to the point of exit at a maximum of 600mm apart. This will provide a short length of pipe to act as a "rocker pipe" and in areas where large settlement is expected more than one may be required.

Under the provisions of BS EN 877, the couplings within the system are designed to function with up to 3° of deflection. It is this allowance along with the short pipe length which permits the movement due to settlement without impeding the function of the pipe system.



### Depth of Pipework

Halifax drainage may be installed under most buildings without additional protection, but when laid under roads with less than 1.2m cover and in areas which are subject to special loadings it is recommended that extra protection be considered.

### Pipe Falls

The pipework gradient should provide a self-cleaning action under normal discharge conditions. For flows of less than 1 litre/sec. gradients of 1 in 40 for 100mm pipe and 1 in 60 for 150mm pipe are usually satisfactory; but in any case, the gradients should not be less than 1 in 80 for 100mm pipe and 1 in 150 for 150mm pipe.

### Provision for Access

Access is required on drainage pipelines to enable the rodding and clearing of any debris and may be provided by manholes, chambers, access fittings or rodding eyes/roddable gullies – the latter allowing downstream access only.

As a general guide, no part of a drain should be further from a manhole than 45 metres and the distance between manholes should not exceed 90 metres. Where one drain connects with another drain without provision of access in the form of a manhole or inspection chamber, access should be provided on the branch drain within 12 metres of the junction. Where the drainage pipeline changes direction either vertically or horizontally; it is recommended an access fitting be incorporated in the design.





### Puddle Flanges

In basement areas where pipes pass through external walls it may be necessary to install a puddle flange. For locations which are below the water table or in areas liable to flooding, puddle flanges will reduce the risk of water entering the building.

Denso tape or similar should be wrapped around the pipe before bolting on the two-piece puddle flange; this will ensure a watertight seal is achieved.

When pipes are installed through pipe sleeves which have been cast into the concrete wall section, it will be necessary to seal the gap between the sleeve and pipe passing through it with a mastic/ sealant.

### Cutting Pipes

Halifax Soil & Drain pipes are easy to cut when shorter lengths are required. We recommend the use of a powered chop saw or disc cutter with the appropriate metal cutting disc fitted" (a manual hacksaw is not practical!) Any burrs or sharp edges should be removed prior to installation to avoid damage to the gaskets. Please see note below regarding paint touch-up.

Caution: – Ensure that eye, respiratory and hand protection are worn at all times when cutting pipes. If power tools are to be used, ensure the area is free from flammable materials/chemicals which may ignite from sparks.

### Touching-Up

Any areas of exposed metal (including cut ends of pipes) should be touched up prior to installation. First any dust, debris or loose paint should be removed then the area should be lightly sanded to ensure good adhesion of paint. The area should then be touched up using a high-quality paint suitable for outdoor use on metallic surfaces.

## Modifications & Testing of Installations

### Modifications to Existing Installations

1. Measure the height of the fitting to be inserted into the existing stack. Add 15mm to this height to allow space for the jointing system.
2. Ensure sufficient support is present in the stack both above and below the location to be cut. If there is any doubt as to the support in place, do not begin modification works.
3. Mark locations on pipe stack to be cut.
4. Cut section out of pipe using a cutting disk or rotary grinder.
5. Remove any burrs, cutting dust and other debris paying particular attention to the sealing zones (approximately 50mm either side of the joint locations)
6. Cut ends should be coated as per the touch-up procedure. Ensure coating is fully cured before proceeding with modifications
7. Insert exposed ends of pipes into coupling gaskets making sure that the central register in the gasket is firmly seated against the pipe ends.
8. Insert fitting into gap. Make sure that the gasket is correctly seated against the fitting both top and bottom and that the central register of the coupling is firmly seated against the pipe ends.
9. Loosely assemble the coupling halves around the gasket and check alignment of the pipe stack.
10. Tighten bolts in couplings to the recommended torque settings (15Nm for Ductile Iron Couplings). Ensure that each side of the coupling is tightened evenly.
11. Conduct testing of the new joints & fitting to ensure modification has been successful.

### Testing of Sanitary Pipework

In accordance with The Building Regulations 2010 – Approved Document H: Drainage and Waste Disposal, clause 1.38:

#### “Air Tightness.

The pipes, fittings and joints should be capable of withstanding an air test of positive pressure of at least 38mm water gauge for at least 3 minutes. Every trap should maintain a water seal of at least 25mm. Smoke testing may be used to identify defects where a water test has failed. Smoke testing is not recommended for PVC-U pipes.”



## Testing of Foul Drainage Pipework

In accordance with The Building Regulations 2010 – Approved Document H: Drainage and Waste Disposal, clause 2.61:

### “Water Test.

For pipes up to 300mm diameter the system should be filled with water up to a depth of 5m above the lowest invert in the test section and a minimum depth of 1m measured at the highest invert in the test section. This may then be left for a period (one hour is generally sufficient) to condition the pipe. The test pressure should be maintained for a period of 30 minutes, by topping up the water level as necessary so that it is within 100mm of the required level throughout the test. The losses per square metre of surface area should not exceed 0.15 litres for test lengths with only pipelines or 0.20 litres for test lengths including pipelines and manholes, or 0.40 litres for tests with only manholes and inspection chambers alone (i.e. no pipelines).”

In accordance with The Building Regulations 2010 – Approved Document H: Drainage and Waste Disposal, clause 2.62:

### “Connectivity.

Where separate drainage systems are provided (see Approved Document H5), connections should be proven to ensure that they are connected to the correct system.”





## Kitemark™ Certificate

This is to certify that:

Hargreaves Foundry Drainage Limited  
Water Lane  
South Parade  
Halifax  
HX3 9HG  
United Kingdom

Holds Certificate Number:

KM 684754

In respect of:

**BS EN 877****Cast iron pipes and fittings, their joints and accessories, for the evacuation of water from buildings**

This issues the right and licence to use the Kitemark in accordance with the Kitemark Terms and Conditions governing the use of the Kitemark, as may be updated from time to time by BSI Assurance UK Ltd (the "Conditions"). All defined terms in this Certificate shall have the same meaning as in the Conditions.

The use of the Kitemark is authorized in respect of the Product(s) detailed on this Certificate provided at or from the above address.

For and on behalf of BSI:

Shahm Barhom, Group Product Certification Director

First Issued: 2018-09-27

Latest Issue: 2024-12-06

Effective Date: 2024-12-06

Expiry Date: 2025-08-16



Page: 1 of 16

This certificate has been issued by and remains the property of BSI Assurance UK Ltd, Kitemark Court, Davy Avenue, Knowlhill, Milton Keynes MK5 8PP, United Kingdom and should be returned immediately upon request.  
To check its validity telephone +44 (0) 345 080 9000. An electronic certificate can be authenticated [online](#).

BSI Assurance UK Limited, registered in England under number 7805321 at 389 Chiswick High Road, London W4 4AL, UK.  
A member of BSI Group of Companies.



- Premier Rainwater & Soil Drainage
- Halifax Sealed/less above & below ground drainage
- Architectural Castings
- Engineering Castings
- Castings Supply



## DECLARATION OF PERFORMANCE No. HF-DOP 1

In accordance with annex III of regulation (EU) No. 305/2011

- 1) Unique identification code of the product type:

**Halifax Soil Cast Iron Pipework System – EN877 Pipe, Couplings & Fittings.**

- 2) Identification of the construction product as required under article 11(4) of the regulation (EU) No. 305/2011:

**Halifax Soil – EN877 Product Range.**

- 3) Intended use or uses of the construction product:

**Above ground conveyance of waste water and rainwater from domestic, commercial & public buildings:**

- 4) Name, registered trade name or registered trade mark and contact address of the manufacturer as required under article 11(5) of the regulation (EU) No. 305/2011:

**Hargreaves Foundry Drainage Ltd**

**Water Lane, South Parade, Halifax, West Yorkshire, HX3 9HG. [www.hargreavesfoundry.co.uk](http://www.hargreavesfoundry.co.uk)**

- 5) Where applicable, name and contact address of the authorised representative whose mandate covers the tasks specified in article 12(2): **Not applicable**

- 6) System or systems of assessment and verification of consistency of performance of the construction product as set out in annex V of the regulation (EU) No. 305/2011:

**System 3 for the reaction to fire & system 4 for all other characteristics.**

- 7) In case of the declaration of performance concerning a construction product covered by a harmonized standard:

**The notifying testing laboratory BRE Global No. 0578, performed the determination of the reaction to fire on samples taken by the supplier, under system 3 and EN877:1999 + A1:2006 incorporating corrigendum 2008.**

**Classification reports for The Halifax Soil Cast Iron pipework system issued:**

- 8) In the case the declaration of performance concerning a construction product for which a European Technical assessment has been issued: **Not applicable**

- Premier Rainwater & Soil Drainage
- Ribbed Socketless above & below ground drainage
- Architectural Castings
- Engineering Castings
- Castings Supply



## 9) Declared performances

Essential Characteristics	Performances	Harmonized Technical Standard
Reaction to fire: -Cast Iron - system	A1 A2-s1, d0	EN877:1999 + A1:2006 incorporating corrigendum 2008.
Internal pressure strength: Water tightness	Conforms	
Dimensional tolerances: External diameter Wall thickness Ovality	Conforms Conforms Conforms	
Impact resistance: Mechanical properties: Tensile strength pipes – min 200 MPa Ring crush strength pipes – min 350 MPa Brinell hardness pipes 260 HB max Tensile strength Fittings – min 150 MPa Brinell hardness Fittings 260 HB max Tensile strength Couplings – min 420 MPa Brinell hardness couplings 250 HB max	Conforms Conforms Conforms Conforms Conforms Conforms Conforms	
Tightness: Gas and liquids Water tightness internal pressure Air tightness internal pressure	Conforms Conforms	
Durability aspects External coatings pipes External coating fittings External coating couplings Internal coating pipes Internal coating fittings	Epoxy – Conforms Epoxy - Conforms Epoxy - Conforms Epoxy - Conforms Epoxy - Conforms	

10) The performance of the product identified in points 1 and 2 in conformity with the declared performance in point 9. This declaration of performance is issued under the sole responsibility of the manufacturer identified in point 4.

Signed for and on behalf of the manufacturer by: Leonard Gill – Technical & QA Manager  
(Name and function)

(Place and Date of issue): Halifax 24/2/2015

Signature 



- Premier Rainwater & Soil Drainage
- Halifax Socketless above & below ground drainage
- Architectural Castings
- Engineering Castings
- Castings Supply



## DECLARATION OF PERFORMANCE No. HF-DOP 2

In accordance with annex III of regulation (EU) No. 305/2011

- 1) Unique identification code of the product type:

**Halifax Drain Cast Iron Pipework System – EN877 Pipe, Couplings & Fittings.**

- 2) Identification of the construction product as required under article 11(4) of the regulation (EU) No. 305/2011:

**Halifax Drain – EN877 Product Range.**

- 3) Intended use or uses of the construction product:

**Below ground conveyance of waste water and rainwater from domestic, commercial & public buildings:**

- 4) Name, registered trade name or registered trade mark and contact address of the manufacturer as required under article 11(5) of the regulation (EU) No. 305/2011:

**Hargreaves Foundry Drainage Ltd**

**Water Lane, South Parade, Halifax, West Yorkshire, HX3 9HG. [www.hargreavesfoundry.co.uk](http://www.hargreavesfoundry.co.uk)**

- 5) Where applicable, name and contact address of the authorised representative whose mandate covers the tasks specified in article 12(2): **Not applicable**

- 6) System or systems of assessment and verification of consistency of performance of the construction product as set out in annex V of the regulation (EU) No. 305/2011:

**System 3 for the reaction to fire & system 4 for all other characteristics.**

- 7) In case of the declaration of performance concerning a construction product covered by a harmonized standard:

**The notifying testing laboratory BRE Global No. 0578, performed the determination of the reaction to fire on samples taken by the supplier, under system 3 and EN877:1999 + A1:2006 incorporating corrigendum 2008.**

**Classification reports for The Halifax Drain Cast Iron pipework system issued:**

- 8) In the case the declaration of performance concerning a construction product for which a European Technical assessment has been issued: **Not applicable**

- Premier Rainwater & Soil Drainage
- Halifax Socketless above & below ground drainage
- Architectural Castings
- Engineering Castings
- Castings Supply



## 9) Declared performances

Essential Characteristics	Performances	Harmonized Technical Standard
Reaction to fire: - Cast iron - system	A1 B-s1, d0	EN877:1999 + A1:2006 incorporating corrigendum 2008.
Internal pressure strength: Water tightness	Conforms	
Dimensional tolerances: External diameter Wall thickness Ovality	Conforms Conforms Conforms	
Impact resistance: Mechanical properties: Tensile strength pipes – min 200 MPa Ring crush strength pipes – min 350 MPa Brinell hardness pipes 260 HB max Tensile strength Fittings – min 150 MPa Brinell hardness Fittings 260 HB max Tensile strength Couplings – min 420 MPa Brinell hardness couplings 250 HB max	Conforms Conforms Conforms Conforms Conforms Conforms Conforms	
Tightness: Gas and liquids Water tightness internal pressure Air tightness internal pressure	Conforms Conforms	
Durability aspects External coatings pipes External coating fittings External coating couplings Internal coating pipes Internal coating fittings	Epoxy – Conforms Epoxy - Conforms Epoxy - Conforms Epoxy - Conforms Epoxy - Conforms	

10) The performance of the product identified in points 1 and 2 in conformity with the declared performance in point 9. This declaration of performance is issued under the sole responsibility of the manufacturer identified in point 4.

Signed for and on behalf of the manufacturer by: **Leonard Gill – Technical & QA Manager**  
(Name and function)

(Place and Date of issue): Halifax 25/2/2015

Signature





Hargreaves  
Foundry  
Drainage

## DECLARATION OF PERFORMANCE No. HF-DOP 3

In accordance with Annex III of Delegated Regulation (EU) No. 574/2014 &  
The Construction Products (Amendment etc.) (EU Exit) Regulations 2019

- 1) Unique identification code of the product type:

**KM001A - Halifax Soil Cast Iron Pipework System designed to meet BS EN 877:1999 + A1:2006 incorporating corrigendum 2008 – Cast iron pipes and fitting, their joints and accessories for the evacuation of water from buildings.**

- 2) Identification of the construction product as required under article 11(4) of the regulation (EU) No. 305/2011:

**Halifax Soil – EN877 Product Range.**

- 3) Intended use or uses of the construction product:

**Above ground conveyance of waste water and rainwater from domestic, commercial & public buildings:**

- 4) Name, registered trade name or registered trade mark and contact address of the manufacturer as required under article 11(5) of the regulation (EU) No. 305/2011:

**Hargreaves Foundry Drainage Ltd**  
**Water Lane, South Parade, Halifax, West Yorkshire, HX3 9HG. [www.hargreavesfoundry.co.uk](http://www.hargreavesfoundry.co.uk)**

- 5) Where applicable, name and contact address of the authorised representative whose mandate covers the tasks specified in article 12(2): **Not applicable**

- 6) System or systems of assessment and verification of consistency of performance of the construction product as set out in Annex V of the regulation (EU) No. 305/2011:

**System 3 for the reaction to fire of the pipe system & system 4 for all other characteristics.**

- 7) In case of the declaration of performance concerning a construction product covered by a harmonized standard:

**The notifying testing laboratory BRE Global No. 0578, performed the initial type testing of the reaction to fire on samples taken by the supplier, under system 3 and EN877:1999 + A1:2006 incorporating corrigendum 2008 – Annex ZA and issued a report for the classification.**

- 8) In the case the declaration of performance concerning a construction product for which a European Technical assessment has been issued: **Not applicable**



Hargreaves  
Foundry  
Drainage

9) Declared performances

All essential characteristics listed in the following table correspond to those described in Annex ZA of BS EN 877:1999 + A1:2006 inc. Corr. 2008.

Essential Characteristics	Performances	Harmonized Technical Standard
<b>Reaction to fire:</b> <ul style="list-style-type: none"> <li>o Cast iron <i>NOTE 1</i></li> <li>o System*</li> </ul>	A1 A2-s1, d0	EN877:1999 + A1:2006 incorporating corrigendum 2008.
<b>Internal pressure strength</b> <ul style="list-style-type: none"> <li>o Water tightness</li> </ul>	Conforms	
<b>Dimensional tolerances:</b> <ul style="list-style-type: none"> <li>o External diameter</li> <li>o Wall thickness</li> <li>o Ovality</li> </ul>	Conforms Conforms Conforms	
<b>Impact resistance:</b> Mechanical properties: <ul style="list-style-type: none"> <li>o Tensile strength pipes</li> <li>o Ring crush strength pipes</li> <li>o Brinell hardness pipes</li> <li>o Tensile strength Fittings</li> <li>o Brinell hardness Fittings</li> <li>o Tensile strength Couplings</li> <li>o Brinell hardness couplings</li> </ul>	min 200 MPa - Conforms min 350 MPa - Conforms 260 HB max - Conforms min 150 MPa - Conforms 260 HB max - Conforms min 420 MPa - Conforms 250 HB max - Conforms	
<b>Tightness: Gas and liquids <i>NOTE 4</i></b> <ul style="list-style-type: none"> <li>o Water tightness internal pressure               <ul style="list-style-type: none"> <li>o Aligned</li> <li>o Deflected</li> <li>o Shear</li> </ul> </li> <li>o Air tightness internal pressure</li> </ul>	$\geq 5$ bar – Conforms $\geq 5$ bar – Conforms $\geq 1$ bar – Conforms $\geq 10$ mbar – Conforms	
<b>Durability aspects <i>NOTE 5</i></b> <ul style="list-style-type: none"> <li>o External coatings pipes</li> <li>o External coating fittings</li> <li>o External coating couplings</li> <li>o Internal coating pipes</li> <li>o Internal coating fittings</li> </ul>	Epoxy – Conforms Epoxy – Conforms Epoxy – Conforms Epoxy – Conforms Epoxy – Conforms	

*NOTE 1:* In accordance with the Commission decision 96/603/EC of 4<sup>th</sup> October 1996, the material is class A1 without the need for testing.

*NOTE 4:* For the purpose of tightness the testing with air is more severe since the air molecules will be smaller than those of gasses normally encountered in drainage systems.

*NOTE 5:* The durability of cast iron is determined by the performance of the coating used. Provided the coating is properly maintained the cast iron products will last indefinitely

\* BS EN877:1999 + A1:2006 inc. corr. 2008 does not allow for fire classifications greater than A2.

10) The performance of the product identified in points 1 and 2 in conformity with the declared performance in point 9. This declaration of performance is issued under the sole responsibility of the manufacturer identified in point 4.

Signed for and on behalf of the manufacturer by:

David Hall – Technical / HSE Manager

Halifax 01/01/2021  
(Place and Date of issue)

Signature 





## DECLARATION OF PERFORMANCE No. HF-DOP 4

In accordance with Annex III of Delegated Regulation (EU) No. 574/2014 & The Construction Products (Amendment etc.) (EU Exit) Regulations 2019

- 1) Unique identification code of the product type:

**KM001B - Halifax Drain Cast Iron Pipework System designed to meet BS EN 877:1999 + A1:2006 incorporating corrigendum 2008 – Cast iron pipes and fitting, their joints and accessories for the evacuation of water from buildings.**

- 2) Identification of the construction product as required under article 11(4) of the regulation (EU) No. 305/2011:

**Halifax Drain – EN877 Product Range.**

- 3) Intended use or uses of the construction product:

**Below ground conveyance of waste water and rainwater from domestic, commercial & public buildings:**

- 4) Name, registered trade name or registered trade mark and contact address of the manufacturer as required under article 11(5) of the regulation (EU) No. 305/2011:

**Hargreaves Foundry Drainage Ltd  
Water Lane, South Parade, Halifax, West Yorkshire, HX3 9HG. [www.hargreavesfoundry.co.uk](http://www.hargreavesfoundry.co.uk)**

- 5) Where applicable, name and contact address of the authorised representative whose mandate covers the tasks specified in article 12(2): **Not applicable**

- 6) System or systems of assessment and verification of consistency of performance of the construction product as set out in Annex V of the regulation (EU) No. 305/2011:

**System 3 for the reaction to fire of the pipe system & system 4 for all other characteristics.**

- 7) In case of the declaration of performance concerning a construction product covered by a harmonized standard:

**The notifying testing laboratory BRE Global No. 0578, performed the initial type testing of the reaction to fire on samples taken by the supplier, under system 3 and EN877:1999 + A1:2006 incorporating corrigendum 2008 – Annex ZA and issued a report for the classification.**

- 8) In the case the declaration of performance concerning a construction product for which a European Technical assessment has been issued: **Not applicable**



Hargreaves  
Foundry  
Drainage

9) Declared performances

All essential characteristics listed in the following table correspond to those described in Annex ZA of BS EN 877:1999 + A1:2006 inc. Corr. 2008

Essential Characteristics	Performances	Harmonized Technical Standard
<b>Reaction to fire:</b> <ul style="list-style-type: none"> <li>○ Cast iron <i>NOTE 1</i></li> <li>○ System*</li> </ul>	<p>A1</p> <p>A2-s1, d0</p>	<p>EN877:1999 + A1:2006 incorporating corrigendum 2008.</p>
<b>Internal pressure strength</b> <ul style="list-style-type: none"> <li>○ Water tightness</li> </ul>	<p>Conforms</p>	
<b>Dimensional tolerances:</b> <ul style="list-style-type: none"> <li>○ External diameter</li> <li>○ Wall thickness</li> <li>○ Ovality</li> </ul>	<p>Conforms</p> <p>Conforms</p> <p>Conforms</p>	
<b>Impact resistance:</b> <b>Mechanical properties:</b> <ul style="list-style-type: none"> <li>○ Tensile strength pipes</li> <li>○ Ring crush strength pipes</li> <li>○ Brinell hardness pipes</li> <li>○ Tensile strength Fittings</li> <li>○ Brinell hardness Fittings</li> <li>○ Tensile strength Couplings</li> <li>○ Brinell hardness couplings</li> </ul>	<p>min 200 MPa - Conforms</p> <p>min 350 MPa - Conforms</p> <p>260 HB max - Conforms</p> <p>min 150 MPa - Conforms</p> <p>260 HB max - Conforms</p> <p>min 420 MPa - Conforms</p> <p>250 HB max - Conforms</p>	
<b>Tightness: Gas and liquids <i>NOTE 4</i></b> <ul style="list-style-type: none"> <li>○ Water tightness internal pressure               <ul style="list-style-type: none"> <li>○ Aligned</li> <li>○ Deflected</li> <li>○ Shear</li> </ul> </li> <li>○ Air tightness internal pressure</li> </ul>	<p>≥ 5 bar – Conforms</p> <p>≥ 5 bar – Conforms</p> <p>≥ 1 bar – Conforms</p> <p>≥ 10 mbar – Conforms</p>	
<b>Durability aspects <i>NOTE 5</i></b> <ul style="list-style-type: none"> <li>○ External coatings pipes</li> <li>○ External coating fittings</li> <li>○ External coating couplings</li> <li>○ Internal coating pipes</li> <li>○ Internal coating fittings</li> </ul>	<p>Epoxy – Conforms</p> <p>Epoxy – Conforms</p> <p>Epoxy – Conforms</p> <p>Epoxy – Conforms</p> <p>Epoxy – Conforms</p>	

*NOTE 1:* In accordance with the Commission decision 96/603/EC of 4<sup>th</sup> October 1996, the material is class A1 without the need for testing.

*NOTE 4:* For the purpose of tightness the testing with air is more severe since the air molecules will be smaller than those of gasses normally encountered in drainage systems.

*NOTE 5:* The durability of cast iron is determined by the performance of the coating used. Provided the coating is properly maintained the cast iron products will last indefinitely

\* BS EN877:1999 + A1:2006 inc. corr. 2008 does not allow for fire classifications greater than A2.

10) The performance of the product identified in points 1 and 2 in conformity with the declared performance in point 9. This declaration of performance is issued under the sole responsibility of the manufacturer identified in point 4.

Signed for and on behalf of the manufacturer by:

David Hall – Technical / HSE Manager

Halifax 01/01/2021  
(Place and Date of issue)

Signature





Cast Iron  
Pipes and  
Fittings  
KITEMARK™  
KM 684754  
BS EN 877